

Mk2 Turntable Manual

for Aurora, Calypso, Resolution & Sovereign

NOTE : Speed must be set accurately after 2 day run in



INTRODUCTION

Read Carefully - Congratulations and thank you for choosing an Origin Live turntable. You now have one of the finest sounding turntables available – not only will it provide an extraordinary level of performance but also reliability and low maintenance. These instructions cover all decks listed on the front cover, so photos and diagrams are for illustration only. Specific instructions for a particular deck are always included.

Critical performance factors should be noted as follows:

Adjustable feet to be clear of plinth

Belt tension as it affects speed

Arm fastening tightness (read carefully as it depends on the arm)

The portions of the instructions printed in grey are optional reading that provide additional information if required. It is critical that the remainder of the instructions are read fully to achieve full potential performance. Underlined text is especially important.

Although the instructions are written for owners with no previous experience of turntables, there are aspects of the deck that run contrary to expectations, so experts should note that before altering anything it is important to have fully read the manual or degradation will result.

An Origin Live turntable is simple to set up. If you have a problem, please refer to the instructions - failing this, you should speak to your dealer or refer to technical support on the Origin Live web site www.originlive.com - See top navigation bar “dealers & information” then “technical support” from the drop down list.

The deck can take approximately 20 minutes to set up depending on your expertise. It can then be played and later on the speed can finally be set with absolute accuracy. As explained later this is because the electronics initially experience speed drift (if they have not been run in) and may need at least a day to run in properly.

We wish you an enjoyable time with your Origin Live turntable.

PREPARATORY NOTES

Your pre-assembled deck is illustrated in the adjacent diagram. It is not necessary or advisable to dismantle the deck.

You might make the mistake of thinking that the sub-chassis is loose but in fact it is designed with freedom to rotate very slightly from side to side but not “rock” up and down much.

AURORA & SOVEREIGN ONLY - Note the anti-rotate stud is replaced by a bolt which is factory fitted to the sub-chassis. This should not be tampered with – it does not bolt to the plinth as its only function is to stop the sub-chassis rotating.

ALL OTHER DECKS - Note “the anti-rotate studs” protrude either side of the inertia disc and locate in the sub-chassis and plinth to prevent rotation.

PARTS LIST

Check that all parts are present.

- Plinth & Sub-chassis - including 1 cable clip with nut & bolt.**
- Turntable bags**
 - o Threaded VTA adjuster
 - o Cork washer for arm
 - o 4mm thick spacer for 3 point mounting on Aurora & Calypso only
 - o Oil bottle
 - o screwdriver
 - o 2.5mm allen key for arm clip
 - o 2 plastic + 1 steel foot (Sovereign only)
- Platter & spindle (+ mat for Sovereign only)**
- (Sovereign only) Sub-platter & sub-platter mat**
- 1 Belt**
- Motor pod**
- Standard or upgrade transformer for 230 volt or 110 volt mains supply**
- Arm (optional)**
- Turntable instructions & Strobe card**

AVOID SCRATCHING THE HIGH GRADE FINISH

To clean the surface use a soft lint free cloth such as a duster – do not use tissue paper or kitchen towel as these are mildly abrasive.

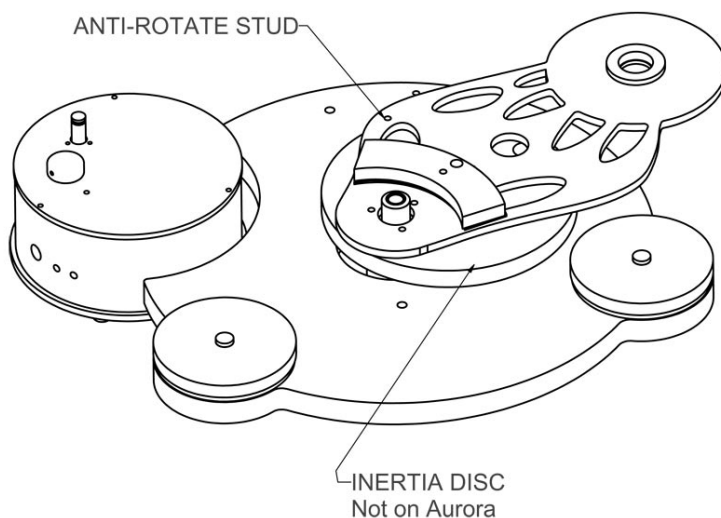

DECK PRIOR TO INSERTING PLATTER

Sovereign deck only - Thread on the 2 plastic feet into the 2 front pods and the steel foot into the rear pod.

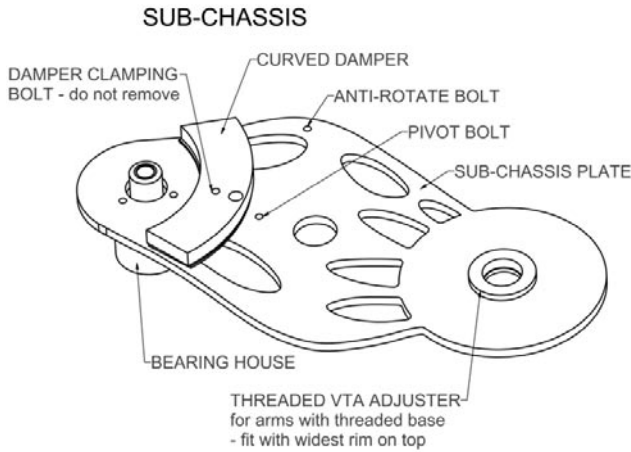

FIT THE TONEARM

Mounting Origin Live arms

Thread the threaded vta adjuster onto your arm if it is an Origin Live Encounter or above. If your deck is a Sovereign and you have an Encounter arm or above - do not fit the threaded vta adjuster. The adjuster must be oriented such that the largest diameter is uppermost. Insert your tonearm into the armboard hole such that the vta adjuster locates centrally. Next fit the cork washer as shown in the diagram below before threading on the large clamping nut. You can set the arm to the correct height later but for now just clamp the arm in position using the large nut. To adjust the height of the arm, screw the vta adjuster up or down and reclamp the arm using the large base clamping nut.

NOTE - For Origin Live arms with integral vta adjuster i.e Encounter and above you should raise the arm height to just below the right level using the threaded vta adjuster and then use the arm vta wheel for fine adjustment.

REAR VIEW OF ARM ON ORIGIN LIVE DECK WITH THREADED VTA AND CORK WASHER

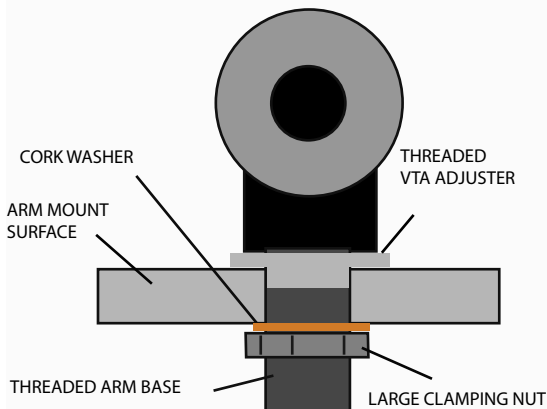

If you have the OL1 or Rega arm with 3 hole mounting

The arm is bolted or screwed to the deck using the 3 mounting holes in the base of the arm. To raise the arm for VTA adjustment you will need to fit 3 or more spacing washers under the arm base holes. One piece spacers are available from Rega if you want a neater looking solution.

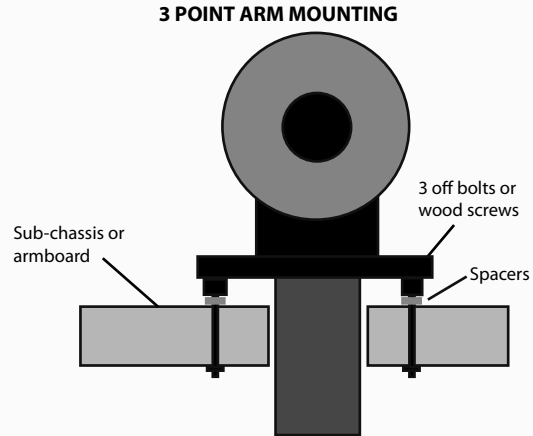

For other makes of tonearm

Origin Live can provide the correct cut out in the sub-chassis or armboard for other makes of arm and after this refer to your arm installation instructions.

FIT THE PLATTER

NOTE - On newer decks (April 2009 onwards) the platter is a "loose" fit over the spindle and can detach from the platter.

Oil the bearing - with the small oil bottle supplied, run approx 10 drops of oil into the top of the bearing house.

Insert the spindle - Wipe the platter spindle surface first to ensure that it is absolutely clean and very gently insert it into the bearing house (If the oil does not overflow when the spindle touches the bottom then try 2 drops at a time till you achieve overflow - wipe away excess oil without withdrawing the spindle. Ideally you should spin the spindle slowly as it settles into the bearing to ensure distribution of oil.

When you oil the bearing you can get a false impression of overflow if the spindle has oil on it - the oil simply scrapes off as the bearing goes in and ends up on the top of the bearing house. You can "feel" overflow when inserting the spindle, it meets resistance at the bottom which is not a "thud" of the spindle hitting the bottom but rather a build up of pressure of the bearing landing on a bed of oil. By further pressing, you can then see the oil being squeezed out at the top. Lastly, if applicable, carefully lower the platter over the spindle till it rests on the lower flange of the platter bush (ensure mating surfaces are clean).

SOVEREIGN DECK ONLY: NOTE - On newer decks (April 2009 onwards) the sub-platter is a "loose" fit over the spindle and can detach from the sub-platter.

Wipe the sub-platter spindle surface first to ensure that it is absolutely clean and very gently insert it into the bearing

house (If the oil does not overflow when the spindle touches the bottom then try 2 drops at a time **till you just achieve overflow** - wipe away excess oil without withdrawing the sub-platter. Next, if applicable, place the sub-platter on the spindle such that the less recessed side is uppermost. Then place the thin black disc on the top of the sub-platter (This is the same diameter as the sub-platter). Lastly, place the platter on top of the sub-platter and follow this with the thin black platter mat .

If you have the heavyweight platter then raise the plinth more than normal by winding out the adjustable feet, till the platter no longer fouls on the motor pod. **The belt must NOT run in the groove of the platter.**

NOTES:

The bearing fit is carefully toleranced to run fully loaded with the specific oil we supply. It needs at least 10 minutes to distribute the oil evenly over the running surfaces and approx 24 hours to properly "run in". It needs this because of the exact tolerances (0.0001") which "float" the bearing off the side walls to avoid metal to metal contact and also minimize viscous drag. Eventually it should run virtually silent when truly vertical and full of oil - if it doesn't do so, there has probably been contamination with dust and you will need to clean it out with a lint free paper towel or similar wrapped around a thin rod. If you do this, be sure to also wipe the oil off the spindle as this also may contain microscopic contamination that is not visible.

Do not use any other oil than Origin Live oil.

Do not tamper with the bolt in the bottom of the bearing or oil leaks will occur and you will probably not succeed in re-tightening it.

The thrust plate at the bottom of the bearing house may appear to be discoloured or dirty - you should not attempt to clean this up as it is part of the hardening process - the centre of the plate is polished as this is the only part that the spindle touches.

The Platter works best **without** any type of mat (including the Ringmat and Sound deadened steel mat).

LEVEL THE DECK

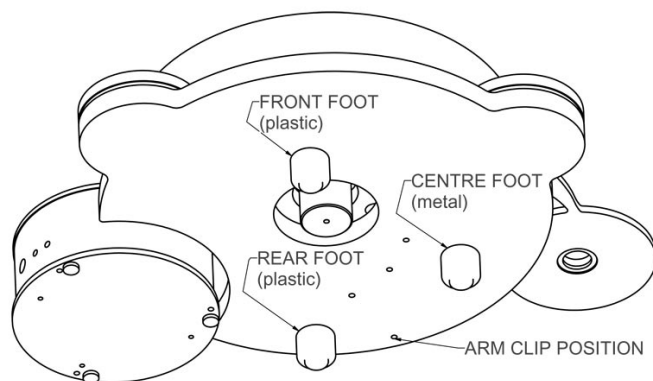

LEVEL DECK BY ROTATING FEET
- always ensure tops of feet are not in contact with underside of plinth

them you can adjust the level of the deck - Rotate all three feet so that the top of the foot does **not** touch the plinth and only sits on the thread alone - this is for best performance. **At this stage check that the bearing house is at least 1mm clear of touching the surface your deck is standing on (Aurora only).**

Note that when you level the deck, the only thing that matters is that the platter (not the plinth) is level. Sometimes there may be a slight discrepancy between the level of the plinth and platter but this does not matter and is usually imperceptible visually.

POSITION MOTOR POD & FIT BELT

Position the motor pod roughly as shown in previous diagrams. The pod should be oriented as shown, such that the switch is at the front. Ideally the centre of the pulley should be somewhere between **210mm (8.25inches) to 221mm (8.7 inches) from the centre of the platter.** **We recommend and set up the speed at factory at 212mm.** The pod must not touch the plinth so rotate it if necessary.

If you don't have a ruler handy another method of setting the belt tension is to install the belt using the method photographed and then lift the belt off the pulley and let it lose its tension whilst still holding it gently - With no tension in the belt, the centre of the pulley should coincide with the inside of the belt as you hold it. If this is not the case, move the pod to achieve correct pulley position. This means that when you hook the belt back over the pulley, you are stretching it about 2 to 3 mm.

Ideal tension for best performance is with the belt as slack as possible - you can fine tune this just by listening to the sound with the pod in slightly different positions.

Insert the power supply jack plug into the pod's largest side hole - see diagram of motor pod. The LED on the top of the pod will light up. Note: green LED is advanced supply and Blue LED is Ultra supply.

Fit the belt over the motor pulley and outer rim of platter. This is most easily carried out by placing the belt in the pulley groove and then holding it there loosely with one finger of your left hand. Whilst retaining the belt in the pulley groove, hold the belt onto the rear rim of the platter with the index finger of your right hand. Now rotate the platter slowly clockwise with your right hand index, all the time pressing the belt on the rim, till the belt is completely on. Allow the motor pulley to rotate under your finger whilst retaining the belt in the groove and maintaining slight tension on the belt between the pulley and rear of platter.

Sometimes the pulley has 2 grooves - this is not for an additional belt (which is not an advantage on OL decks) but is to allow greater levelling capacity due to feet adjustment.

The 3 feet under the plinth are all threaded so that by rotating

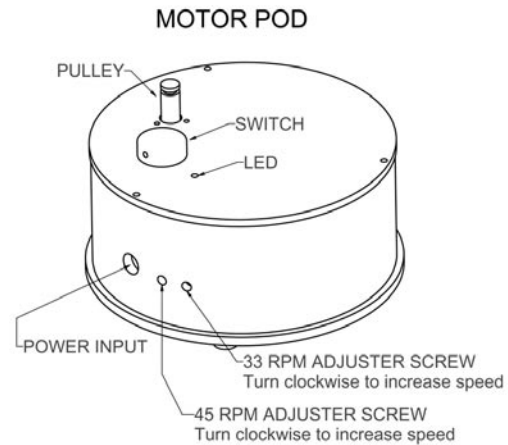
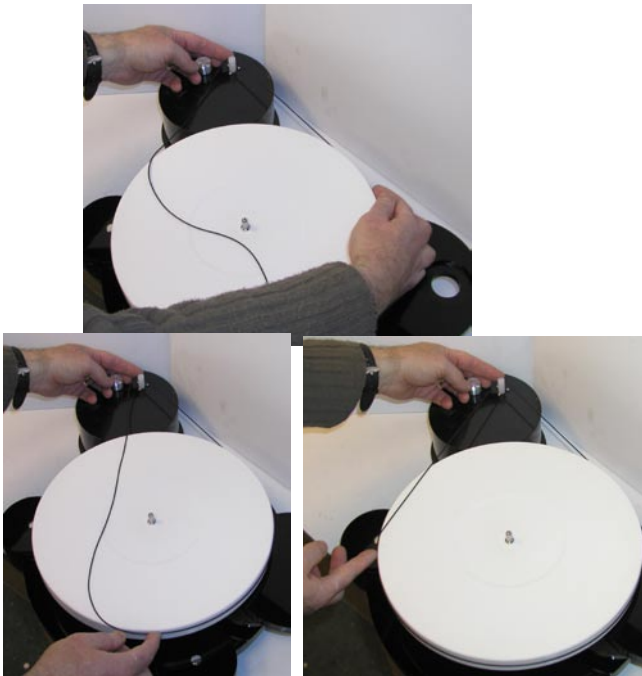

When the rotary switch on the pod is turned fully anti-clockwise and the line on the knob aligns to the LED, the motor is off.

One click of the switch clockwise is 33.3 rpm - The second click clockwise is 45rpm

Set the belt tension by positioning the motor housing. The belt has an ideal tension for best performance - too tight and motor bearing friction increases causing possible speed instability and increased wear plus a decrease in sonic performance. The correct distance is not hypercritical to performance and the above dimensions may need to be increased after a year of use due to belt stretch. Experiment with different distances if you wish for best sound but you may need to adjust speed between different distance settings, as speed varies slightly with different belt tension.

Do not plug the power supply into mains conditioners, filters or anything with surge protection - this can be disastrous to performance. It will not harm the pod, to plug it into the aforementioned items but it almost always results in performance degradation.

The location of the motor pod should preferably be kept away from strong electromagnetic fields typically generated by transformers, amplifiers, power supplies etc.

SETTING THE MOTOR SPEED

You will need to set the motor speed yourself. In the first 24 hours of use from starting up the motor, the speed tends to drift but then settles down permanently. To burn in the regulator board components we recommend at least 24 hours of running the motor before setting the speed - **the platter bearing also takes time to bed in so motor running in should be carried out with platter turning (no faster than 45rpm).**

The thin output wires from the transformer only carry a very low voltage and are therefore safe to handle. Voltages inside the transformer are dangerous so the transformer case should not be unscrewed or opened.

NOTES: The speed should only be finally set with the pod in it's FINAL position and at normal room temperature as speed varies slightly with belt tension and temperature.

If you move the pod, you will need to re check the speed and if necessary correct it, by repositioning the pod till the speed is correct. This is a quick operation if you leave the platter spinning as you slide the pod to adjust tension. Also it is best checked with the cartridge dragging on a centre track of a record as the drag can affect speed setting to a small degree. Do not move the pod beyond the ideal distances mentioned in "fitting the belt".

If you change transformer to the upgrade transformer you will need to reset the speed.

If the speed drifts significantly then correct it using the speed adjuster screws.

Instructions for reading the strobe

Place the strobe disc on the record to be played. Play the record and watch the relevant ring on the disc. Adjust the speed until marks on the ring appear stationary while the record is rotating. It sometimes helps to stare at infinity whilst doing this as the marks become easier to see. You can see the strobe effect in fluorescent light, although an ordinary bulb held about 2 feet from the strobe disc will also work fine. The bulb flickers at 50 Hz in the EEC and 60 Hz in the USA.

You can purchase bayonet fitting fluorescent bulbs to fit normal lamps. Try to shut out daylight when carrying out speed setting.

Set the speed

Set the switch on the pod to the first click i.e. 33 rpm setting. Adjust the motor speed as follows: using the small screwdriver, turn the speed adjuster screw shown in the photo for 33 rpm. This is accessible through the hole in the side of the pod and the slots in the screw heads are visible if you look into the holes (See diagram below).

To increase speed, turn the screw clockwise until the speed

changes. If the screw reaches the end of its travel you can usually hear a faint clicking. You will not damage the preset by over turning it as slippage occurs. The preset screw will not fall out and may in some cases need a number of turns to set the correct speed so keep turning.

Setting the 33.3rpm. When setting the speed, place the arm on the centre track of a record so that the cartridge is tracking the grooves this ensures that the drag of the cartridge is taken into account. Speed variations of up to plus or minus 2% are quite common on decks and the dc motor is capable of plus or minus 0.1% accuracy. Use the strobe disc provided to set the speed (full instructions are on the card).

Click the rotary switch to the 2nd click clockwise and set 45rpm speed so that the platter rotates at 45 (or 78 rpm if you wish) using the same procedure as for 33rpm.

The dc motors are slightly noisy to begin with and are never completely silent in comparison to a/c motors. This is thought to be due to a different type of precious metal brush. Having said this they still sound a great deal better in performance terms.

Like most turntable manufacturers we recommend that you leave the turntable running between changing records as this reduces the belt wear that occurs with constant stopping and starting.

NOTES ON MOTOR & SPEED SETTING

-Do not use the power supply for anything other than the dc motor or the power supply is highly likely to be irreparably damaged and you could also damage the equipment you are plugging it into.

-The circuit will take at least 4 days to fully run in and sound it's best. For this reason it is best to do a final speed check at the end of this period.

The speed stability of your deck will be excellent once everything has settled down in a listening session.

When checking speed - ensure that the power supply and switch box have been plugged in for at least 3 hours. The platter also needs to run for 5 minutes with the cartridge on the record for at least 10 seconds.

It is highly preferable to keep the transformer plugged in at all times (unless you are away on holiday) because it takes a good 3 hours to warm up from cold and run at it's best. When in stand by mode the control box draws a negligible current so you needn't worry about your electricity bill.

FINAL SETUP OF TONEARM

Refer to your tonearm installation and fitting instructions and use the following only as a rough guide on issues specific to the turntable. **VERY IMPORTANT NOTE - Do not use the serrated washer supplied with some Origin Live arms - it is only meant for non-metalic armboards and degrades Origin Live decks very significantly.**

VTA (vertical tracking adjustment)

To allow the cartridge needle to track at the correct angle it is important that the base of the arm is at the correct height in relation to the platter - this can be set by rotating the chrome

threaded VTA adjuster supplied with the deck for Origin Live and Rega derived arms. One complete turn of the adjuster clockwise raises the arm 1mm.

Set the arm fastening tightness

It is best to experiment with the tightness of the large base nut (if fitted) by listening to music. This may seem laborious but you will be richly rewarded as this adjustment makes a big difference to performance.

IMPORTANT TIP: For Origin Live **dual pivot** arms tighten the arm bottom nut fairly hard, but for OL1, Rega and Silver arms use minimum tension on the fastening nut.

Fit the arm cable clip

Pass the arm cable through the cable clip and fasten in position with the nut & bolt supplied. Leave a slight droop on it so that it isn't "tight". The clip fastens to the underside of the plinth using the hole near the rear foot. This is helpful to "earth" vibration in the cable. The earth lead should be connected to the earth of your pre-amplifier or amplifier. This earth lead is best separated slightly from the arm signal leads so do not wind it around them for best performance.

UPGRADES

It is possible to upgrade the turntable

Further upgrades would be

- DC200 motor in the case of the Aurora and Calypso
- Upgrade Transformer - (Sovereign comes with this included as standard)

MAINTENANCE OF DECK

It aids performance to clean all the running surfaces every 3 months or so with mentholated or surgical spirit.

To clean the deck, use a damp soft lint free cloth and wipe gently – if you have grease marks etc then you can use a general-purpose anti-smear, car window cleaner such as Autoglym Fast glass, but only if necessary – wax furniture polish is to be avoided . Do not spray directly on the turntable as it may clog up the cartridge etc but rather spray onto a soft polishing cloth and then use it on the turntable. Do not use tissue paper or kitchen cleaning paper towels as paper is abrasive and can put faint scratches in the polished surface.

If you do get minor abrasions on the surface then you can remove them using a fine car paint abrasive polish such T-cut or Autoglym paint renovator - this is especially usefull to remove stubborn grease marks on the platter.

It is wise to keep the packing box that the turntable came in so that you can transport the deck securely.

The deck is not prone to going out of tune - we recommend that you check the sub chassis damper is tensioned lightly onto the plate every 2 years or so as the damping can compress a little over time.

Depending on your use of the deck, the belt should ideally be replaced every 2 years or so.

If you withdraw the sub-platter spindle more than a few times you should put in a drop of oil to compensate for any possible loss.

the 3 screws holding the motor to the top plate.

If you have checked the above and are still having trouble please contact us .

TROUBLESHOOTING

Omit reading this greyed out section unless you have a problem

SPEED VARIATION

If there is significant speed variation then possible causes are as follows.

- Significant changes in room temperature - this affects the viscosity of the oil in the bearing.
- Lack of oil in the bearing so check by adding oil.
- Changed belt tension or an oily belt or platter - clean running surfaces.
- Turntable out of level – this affects the main bearing friction.
- After adjusting the tension of the 3 small Philips screws which hold the motor on, you may need to re-adjust the speed as they affect motor bearing friction very slightly.
- Check the platter is not fouling on anything.
- A dirty bearing that exhibits too much friction - The platter should drift round effortlessly with the slightest of nudges and go on spinning. If you suspect the bearing friction to be a little high return the bearing to us for checking.
- A worn thrust bearing - this may occur after many years of continuous use in common with all turntables.
- Transistors that have developed temperature instability.
- Most of the pulleys are a push fit on the motor shaft - however they can sometimes work loose in transit or in use. If this is the case then you can easily rectify it by lightly tapping the pulley back onto the spindle with your fingers - Do not use a hard object or excessive force as this can damage the spindle.

EXCESSIVE MOTOR NOISE

The motor needs a run in time of around 1 - 2 days continuous running. They are sometimes a little noisy to start with. It is best to run in the motor on full power with the belt off. Most importantly you can “tune in” the motor to give minimum noise by adjusting the tightness of the 3 small Phillips screws next to the motor pulley. The best way to set their tension is to tighten the screws until they just nip tight. Then back off all 3 screws a little way. Now tighten one screw at a time till you hear which ones cause the least noise when tensioned and then adjust the other two to give minimum noise. It may be necessary to use thread lock or similar to stop the screws vibrating loose. If it continues to be very noisy please get back to us and we may check it out. However bear in mind that the dc motor is never as silent as a/c motors are - this is because they are cogless and rely on a different type of brush. Having said this dc motors still sound a lot better in terms of musical performance.

The other major potential source of noise is the motor vibrating due to lack of tightness and causing it's top plate to resonate. The solution is usually to slightly tighten the 3 small screws holding on the motor. This adjustment is fairly critical - if the 3 small screws are too tight then the motor whispers, too slack and the motor can vibrate against it's top plate.

If you get a knocking sound from the motor then slightly slacken off

REPACKING METHOD

Please read carefully and do not deviate, do not cut up foam etc or damage will result - see separate sheet for Sovereign packing instructions.



Ensure base foam is in position in box as shown



Wrap plinth in polythene bag and place on bottom layer of foam - ensure that feet and bearing house all locate in holes in foam. The hole for the rear foot is marked with an R

Place top layer of foam on top of plinth - top foam has no holes in it.

Place components on top layer of foam as show below

Wrap platter in polythene bag then tape blue edging foam to protect edges - lastly place thick foam square over long length of shaft - place in corner of box , upside down as shown.

Instruction manual

Arm if included larger arms will not fit - i.e Encounter and above



Wrap motor pod in polythene and then tape cardboard tube with slit round the pod - the tube sits on top of the base plate, not round it. This is to provide protection against anything that might knock the end of the motor shaft as this can cause damage. Note that the motor pod must be positioned in this corner of the box where there is the greatest depth i.e not over the plinth armboard

Place the wallwort transformer in the remaining cardboard tube as shown and then place the bubble bag containing the following items on top of the transformer

Bag contains - threaded vta adjuster, Oil bottle, screw driver, 2.5mm allen key

Place the strobe card and belt in the top of the motor pod card tube.