



*O*RIGIN LIVE

AURORA INSTRUCTIONS

C O N T E N T S

Introduction (read carefully)	3
Parts list	3
SET - UP	4
FIT THE SUBCHASSIS	4
FIT THE MOTOR POD	5
Fit the tonearm	5
Fit the sub-platter & platter	5
Level the deck	6
Connecting up the power supply.	6
Setting the motor speed	7
Instructions for reading the strobe	7
Set the speed	7
Final checks	8
Maintenance of turntable	9
Troubleshooting	10
FINAL SETUP OF TONEARM	10
Installing the arm	10
Introduction	10
VTA (vertical tracking adjustment)	11
Using the Origin Live VTA sliding adjuster	11
Fit the arm cable clip	11
Arm & cartridge set up	11
Fit the cartridge (if not fitted already)	11
Set tracking force & side force bias	12
TRACKING FORCE	12
Use of Stylus force guage	12
SIDE BIAS FORCE	12
Set the VTA (vertical tracking adjustment)	13
Set the arm fastening tightness	13
Warranty	14
Notes	14
HI-FI CARTRIDGES - SET-UP PROCEDURES	15
Introduction	15
General comments	15
Importance of cartridge set up	15
Levelness	15
Hi-fi cartridges alignment	15
Hi-Fi cartridge aligning tools	16
Check hi-fi cartridge clip connections and mounting	16
Setting up hi-fi cartridges	16
Mounting	16
Tracking Force	17
Tangency Alignment	17
Vertical Tracking Angle (VTA)	17
Antiskate Force (pivoting arms only)	17
Fine Tuning	17
PROPER CARE AND MAINTENANCE OF HI-FI CARTRIDGES & RECORDS	19
Care of hi-fi cartridges	19
Record care and cleaning	19

INTRODUCTION (READ CAREFULLY)

Congratulations on choosing your Origin Live turntable. You now have one of the finest sounding turntables available – not only will it provide an extraordinary level of performance but also reliability and low maintenance.

The portions of the instructions printed in blue are optional reading for more in depth knowledge if necessary. It is critical that the remainder of the instructions are read fully to achieve the full performance from your turntable. There are aspects of the deck that run contrary to what you may expect, so before altering anything it is important to have fully read the manual or degradation will result.

The Aurora turntable is simple to set up. If you have a problem please refer to the instructions. If your problem persists you should speak to your dealer or have a look at the Origin Live web site www.originlive.com under “general information” then “technical support” from the drop down list

The instructions are written for people with no previous experience of turntables. Some sections may therefore appear lengthy, as they need to cater for all potential questions. When reading the instructions refer to the various diagrams for part names and clarity.

The deck can take approximately 15 minutes to set up depending on your expertise. The dc regulator electronics may initially encounter speed drift when first started (if they have not been run in) and may need at least 4 hours to run in before the speed can finally be set with accuracy.

We wish you an enjoyable time with your Aurora turntable.

PARTS LIST

- Plinth
including 1 cable clip and attachment nut & bolt
Pivot bush, nut and bolt attached.
- Turntable bag
 - o Belt
 - o Oil syringe
 - o 3mm & 2.5mm Allen keys
 - o Tube to extend Allen key
 - o 3 cork disks
- Platter
- Sub-platter
- Sub-chassis
- Motor housing
- Control box
- Transformer for 230 volt or 110 volt mains supply
- Arm (optional)

PAPERWORK

- Turntable instructions
- Strobe card

Set-up

Unpack all parts and check they are all present.

FIT THE SUBCHASSIS

Place the 10mm deep chrome pivot bush precisely over the hole shown in the photo below. Note the anti-rotate bolt is factory fitted and should not be touched – nothing is bolted to it as it’s only function is to stop the sub-chassis rotating.

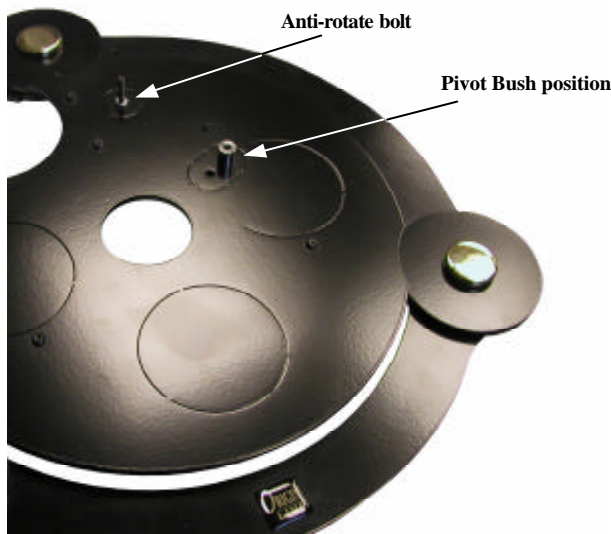

Now place the subchassis on top of the pivot bush making sure that orientation is such that

1. The anti-rotate bolt goes through the hole in the sub-chassis as shown below
2. The hole for the pivot bolt is over the hole in the chrome pivot spacer.

Insert the black pivot bolt from the top, so that it passes through the sub-chassis first then the pivot spacer tube and finally the inner plate of the plinth. Secure the pivot bolt under the plinth with the lock nut supplied and tighten sufficiently to pull the sub-chassis level. One way of checking that you have the correct position for the sub-chassis is that the bearing house will go through the CENTRE of the large circular cut out in the centre of the inner plate.

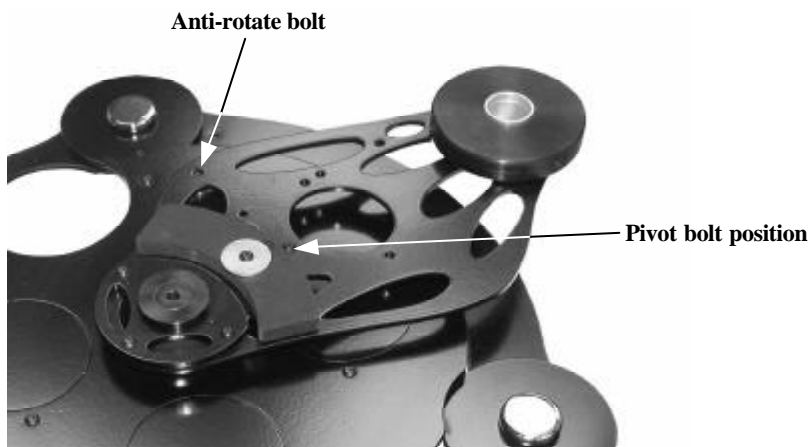

When tightening the pivot nut it is important that it is not tensioned up too tightly. The subchassis should be able to rotate very slightly from side to side but not “rock” up and down much. This adjustment is fairly critical to obtain optimum performance. You can experiment with various bolt tensions and listen for what sounds best –

this exercise will be rewarded. If the bolt is done up too tightly there will be degradation in the performance – too slack and the sub-chassis may sag obviously to one side (a little sag is not a problem).

FIT THE MOTOR POD

Place the motor pod on the surface where your deck is going to take up residence. Lower the plinth over the motor pod. The pod should sit roughly centrally in the plate circular cut out for the motor and not touch the plinth.

FIT THE TONEARM

Insert your tonearm into the aluminium sleeve located in the circular arm mounting plate (armboard). You can set the arm to the correct height using the setscrew located in the arm board as shown in the photo below. This setscrew clamps the aluminium sleeve onto the arm board. Further to this, when clamped very hard, it deforms the aluminium sleeve sufficiently onto the threaded arm base to allow it to clamp the arm in position – to achieve this level of force, you can use the small length of tube supplied. When this is slid over the end of the Allen key it acts as an extension thus allowing you to exert better leverage as shown in the photo below.

It doesn't matter whether you slide the aluminium sleeve up and down in the arm board to get the height right or slide the threaded arm base in the aluminium sleeve. Both methods work fine. Note that you should NOT clamp the aluminium sleeve hard when there is no arm fitted inside. If you do this, then permanent deformation will result – the slightest of “nips” is all that is necessary before the arm is fitted. You do not need to fit the large arm base nut, or any of the washers. To obtain accurate VTA setting you can mark the aluminium sleeve with pencil lines to keep track of trial positions.

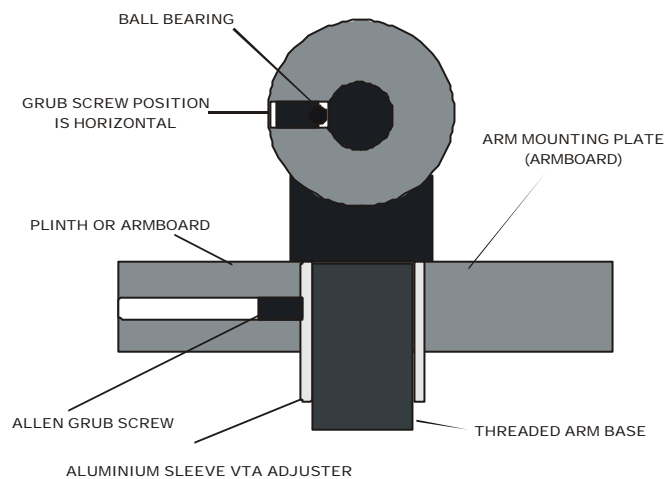

FIT THE SUB-PLATTER & PLATTER

Oil the bearing - with the syringe supplied, run approx 5 drops of oil into the top of the bearing house.

Insert the sub-platter - Wipe the sub-platter spindle surface to ensure that it is absolutely clean and very gently insert the sub-platter into the bearing house (If the oil does not overflow when the spindle touches the bottom then try 2 drops at a time till you just achieve overflow - wipe away excess oil) and then place the platter on top.

NOTE:

The bearing needs a few minutes to “run in” and should run silent when truly vertical and full of oil - *if it doesn't do so, there has probably been contamination with dust and you will need to clean it out with a lint free paper towel or similar wrapped around a thin rod. If you do this, be sure to also wipe the oil off the spindle as this also may contain microscopic contamination that is not visible.*

Fit the belt over the motor pulley and sub-platter.

Set the belt tension by positioning the motor housing relative to the turntable. Ideally the centre of the pulley should be approximately 124mm from the centre of the bearing house.

Note: It is very common for people to set the belt tension too tight, which can slightly degrade performance. The optimum setting is where there is enough tension to turn the platter without audible wow and flutter but no more. This may take some experimentation.

It also aids performance to clean all the running surfaces with mentholated or surgical spirit.

Ensure that the motor pod is not touching the plinth.

Place the platter on the sub platter. The motor pod should be positioned such that the pulley is situated inside the rim of the platter. To adjust the tension of the belt, move the motor pod towards or away from the centre of the turntable. The belt should be tight enough to turn the platter with out any wow or flutter but not be set too tight because this will degrade the performance.



Photo showing motor pod and sub-platter added.

Level the deck

To check the level of the turntable always use the platter as your reference, not the plinth, as there is usually a very slight discrepancy. Fine levelling of the deck is possible by either levelling the support that the turntable is standing on or alternatively you can insert the cork discs supplied under one of the rubber feet.

CONNECTING UP THE POWER SUPPLY.

Now that you have positioned the motor pod you need to plug in the control box and transformer.

1. Plug the smaller male dc connector from the motor into the left hand of the two holes at the back of the control box (See Fig A below)
2. Plug the male dc connector from the transformer (low voltage input) into the right hand socket (when looking at the back of the box) another way of describe it is the socket directly behind the LED.
3. You will know that the motor kit is connected up correctly when the LED comes on (This light will remain lit all the time that the motor kit is plugged in at the mains supply).

The location of the control box should preferably be kept away from strong electromagnetic fields such as those generated by transformers, amplifiers, power supplies etc.

NEVER LEAVE THE POWER SUPPLY PLUGGED IN IF THE CONTROL BOX IS DISCONNECTED FROM IT – In rare cases this can damage the transformer.

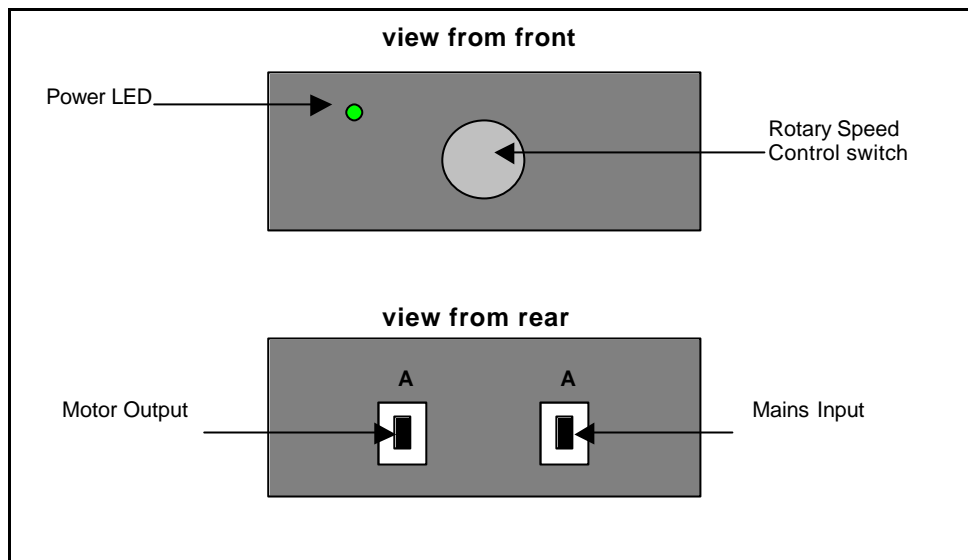

FIG A

SETTING THE MOTOR SPEED

NOTE:

You will need to set the motor speed yourself. In the first 4 hours of use from starting up the motor, the speed tends to drift but then settles down permanently. To burn in the regulator board components we recommend at least 4 hours of running the motor before you accurately set the speed.

The thin output wires from the transformer only carry 8 volts and therefore safe to handle. Voltages inside the transformer are dangerous so the transformer case should not be unscrewed or opened.

The switch box is designed such that when the rotary switch on the front of the control box is turned fully anti-clockwise the motor is off. One click of the switch clockwise is 33.3 rpm and the second click clockwise is 45rpm.

NOTE: The speed can only be finally set or checked with the cartridge dragging on a centre track of a record as the drag affects speed setting.

Instructions for reading the strobe

Place the strobe disc on the record to be played. Play the record and watch the relevant ring on the disc. Adjust the speed until marks on the ring appear stationary while the record is rotating. It sometimes helps to stare at infinity whilst doing this as the marks become easier to see. You can see the strobe effect in florescent light although an ordinary bulb held about 2 feet from the strobe disc will also work fine. The bulb flickers at 50 Hz in the EEC and 60 Hz in the USA.

You can purchase bayonet fitting florescent bulbs to fit normal lamps. Try to shut out daylight when carrying out speed setting.

Set the speed

Adjust the motor speed as follows: using a small flat blade screwdriver turn the screws of the 25 turn resistors P1 and P2 on the regulator board. These are accessible through the hole in the underside of the control box (See diagram below). P1 is for the 1st speed 33 rpm and P2 45 rpm. To increase speed, turn the presets clockwise until the speed changes. If the screw reaches the end of it's travel you can usually hear a faint clicking. The pre-set screw will not fall out and may need a fair number of turns to set the correct speed so keep turning

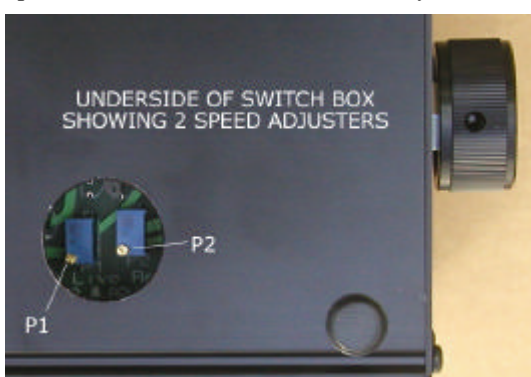

If this photo is not quite the same as your control box you can identify P1 & P2 as they are labelled on the circuit board.

Set the switch on the control box to the first click i.e. 33 rpm setting.

Set P1 so that the platter turns at 33.3rpm. When setting the speed, place the arm on the centre track of a record so that the cartridge is tracking the grooves this ensures that the drag of the cartridge is taken into account. Speed variations of up to plus or minus 2% are quite common on decks and the dc motor is capable of plus or minus 0.1% accuracy. Use the strobe disc provided to set the speed (full instructions are on the card). **However if you have problems using the strobe card, then count the rpm using the following method. Counting the 33.3 revs per minute is best accomplished by placing a small piece of sticky tape on the perimeter of the platter and then counting 100 revolutions. 33.3 rpm is exactly 100 revolutions completed in 3 minutes. To save time in the early stages it is easiest to count 50 revs in 1 minute 30 seconds (or 25 revs in 45 seconds) and save the 100 count for the final check.**

Please note the following points when setting the speed. Firstly all the figures below are based on setting the speed on the deck using the centre track and letting the deck play for a good 5 minutes beforehand with the stylus on the record so that the whole system has settled down. The regulators seem to take about 5 minutes to warm up, **so speed is about 2mins 58 seconds for 100 revolutions when the system starts from cold. In other words it is $2/180 \times 100 = 1\%$ fast when started from cold.** Speed variation with the dc motor varies minutely depending on the track played and cut of record.

Click the rotary switch to the 2nd click clockwise and set P2 so that the platter rotates at 45 or 78 rpm (if you wish) using the same procedure as outlined above.

The dc motors are noisy to begin with and are never completely silent in comparison to a/c motors. This is thought to be due to a different type of precious metal brush. Having said this they still sound a great deal better in performance terms. To assist "running in" you can turn the speed right up via the control box. The motor then runs at high speed. Allow this for approx 4 hours. After the running in period reset the motor speed. The motor should then be run for approx 3 days under load (i.e. turning the platter) to free it up from vibration and to "bed in" the bearings.

Like most turntable manufacturers we recommend that you leave the turntable running between changing records as this reduces the belt wear that occurs with constant stopping and starting.

NOTES ON MOTOR & SPEED SETTING

-Do not use the power supply for anything other than the dc motor or the power supply will definitely be irreparably damaged and you could also damage the equipment you are plugging it into.

-The circuit will take around 8 hours to run in and sound it's best.

The speed stability of your deck should be excellent once everything has settled down in a listening session i.e..

The power supply and switch box have been left plugged in on standby for 15 minutes, the platter has been turning for 2 minutes and the cartridge has been on the record for 30 seconds. Bear in mind that the ear detects when music is playing slightly slow much more easily than it detects it playing fast. For this reason most manufacturers set their decks to run slightly fast. You can expect a bit of speed variation when the motor is first switched on - it takes about 2 minutes to warm up properly and then the motor should run at it's correct speed but only when the stylus is on the record. It is highly preferable to keep the transformer plugged in at all times (unless you are away on holiday) because it takes a good 15 minutes to warm up from cold and run correctly. When in standby mode the control box draws a negligible current so you needn't worry about your electricity bill.

If you keep switching the deck on and off you will get a little speed variation as it takes approx 2 minutes to warm up the circuit each time even if it's only switched off for 3 seconds. This is unavoidable although we have tried to design out the variation as much as possible.

If you measure the speed without a needle on the record the speed will not be perfect, as the speed should only be set with the stylus tracking the record. If you don't do this, the record will run slow once you put the stylus on the record.

If you measure the speed within 30 seconds of putting the needle on the record the speed will not be perfect as it takes a while to settle down.

Some people make the mistake of constantly watching the speed before the deck has settled down and the needle has been on the record for a good 2 minutes. Strobes are very accurate and the slightest speed variation is picked up. 0.03% variation is observable which is over 30 times the accuracy of mid-priced decks on the market.

FINAL CHECKS

Your turntable is now ready to use. The following checks make sure that you have set up the turntable correctly.

The motor pulley must not foul the underside of the platter and should be inside the platter rim.

- ❑ The tonearm should be set up with correct VTA i.e. the tube should be approx parallel to the surface of the record – see the tonearm instructions about this as it is important to get the right sound and is often a matter of experimentation.
- ❑ With the tonearm and cartridge mounted, check that the platter is level – if not, then level it by levelling the table or surface that the deck stands on. If this is not possible then use a combination of the spring height adjuster and cork disc(s) placed under one of the rubber feet of the deck. We understand that this may not seem the most elegant solution but threaded adjusters would sacrifice sound quality significantly.
- ❑ Ensure that there is a little “bounce” on the arm end of the sub-chassis. If not then check that the top chrome spring adjuster is not touching the top of the spring support bolt, as this will render the whole suspension system ineffective.
- ❑ Checking the sub-platter
 - ❑ The sub-platter spins freely and does not touch the bearing house or anything else.
 - If the sub-platter is rubbing on the top spring height adjuster you need to loosen the bearing house by unscrewing the lower round bearing case – then thread the bearing house upwards and retighten. There should be at least 1-2mm clearance between the spring top adjuster and the sub platter at all times.
- ❑ Checking the platter
 - ❑ The platter spins freely and does not touch the motor pulley or anything else.
 - If the platter catches on the top of the pulley you can adjust the height of the bearing house by unscrewing it and threading it upwards. This is very rare.
- ❑ CHECKING THE MOTOR
 - ❑ Check that the motor housing is not touching the plinth at any point.
 - ❑ Check that the motor is tuned correctly as above.
 - ❑ Check that the belt is not rubbing on either of the flanges on the top and bottom of the spindle. If it does try tightening the belt or see motor tuning.

M A I N T E N A N C E O F T U R N T A B L E

To clean the deck, use a soft lint free cloth and wipe gently – if you have grease marks etc then you can use a general-purpose anti-smear polish such as Mr Sheen but only if necessary – wax furniture polish is to be avoided and if possible use an anti-static type of polish. Do not spray the polish on the turntable as it may clog up the cartridge etc but rather spray it onto a soft polishing cloth and then use it on the turntable.

The Platter works best **without** any type of mat (including the Ringmat).

It is wise to keep the packing box that the turntable came in so that you can transport the deck securely. Be careful in moving or transporting the deck - it is possible to bend the spring support bolt if a severe side movement occurs (bear in mind that the sub-chassis etc. is quite heavy). Ideally it is best to remove the subchassis from the deck when transporting the deck.

The deck is not prone to going out of tune - we recommend that you check the level of the platter after the first few days as the spring initially “beds in” and every year or so after this.

Depending on your use of the deck, the belt should ideally be replaced every 2 years or so.

If you withdraw the sub-platter spindle more than a few times you should put in a drop of oil to compensate for any possible loss.

In the unlikely event that the support rod becomes loose over time such that it can “rocks” then the nuts need to be re-tightened. Only “nip” the nut tight by a maximum of 1/8th of a turn after finger tightness has been achieved and it starts to clamp onto the steel.

TROUBLESHOOTING

SPEED VARIATION

If there is significant speed variation then possible causes are as follows.

- Significant changes in room temperature - this especially affects decks that use thick, viscous oil in the bearings e.g. Rega decks
- Lack of oil in the bearing so check by adding oil.
- Changed belt tension or an oily belt or sub-platter - clean running surfaces.
- Turntable out of level – this affects the main bearing friction.
- After adjusting the tension of the 3 small Phillips screws which hold the motor on, you may need to re-adjust the speed as they affect motor bearing friction very slightly.
- Check the sub-platter is not fouling on anything - on certain decks it can rub against one of the spring covers - it has also been known to "bottom" against the top of the bearing house - there should be about 1 to 3mm clearance between the top of the bearing house and the bottom of the sub-platter.
- A dirty bearing that exhibits too much friction - The sub-platter should drift round effortlessly with the slightest of nudges and go on spinning. If you suspect the bearing friction to be a little high return the bearing to us for checking.
- A worn thrust bearing - this may occur on a small run of bearings, which were too soft.
- Transistors that have developed temperature instability.

EXCESSIVE MOTOR NOISE

The motor needs a run in time of around 2 - 4 days continuous running. They are sometimes a little noisy to start with. It is best to run in the motor on full power with the belt off. Most importantly you can "tune in" the motor to give minimum noise by adjusting the tightness of the 3 small Phillips screws next to the motor pulley. The best way to set their tension is to tighten the screws until they just nip tight. Then back off all 3 screws a little way. Now tighten one screw at a time till you hear which ones cause the least noise when tensioned and then adjust the other two to give minimum noise. It may be necessary to use thread lock or similar to stop the screws vibrating loose. If it continues to be very noisy please get back to us and we may check it out. However bear in mind that the dc motor is never as silent as a/c motors are - this is because they are cogless and rely on a different type of brush. Having said this dc motors still sound a lot better in terms of musical performance.

The other major potential source of noise is the motor vibrating due to lack of tightness and causing it's top plate to resonate. The solution is usually to slightly tighten the 3 small screws holding on the motor. This adjustment is fairly critical - if the 3 small screws are too tight then the motor whispers, too slack and the motor can vibrate against it's top plate.

Please note that by adjusting these screws you affect the angle of the motor. If the belt touches the flanges at the top or bottom of the pulley then the motor is at too extreme an angle and you will need to re-adjust the bolts.

The ideal is for a vertical pulley with the lowest noise level. If you get a knocking sound from the motor then slightly slacken off the 3 screws holding the motor to the top plate.

If you have checked the above and are still having trouble please contact us making a note of the serial number on the back of the control box.

Final setup of tonearm

INSTALLING THE ARM

Introduction

Rega arms and Origin Live arms require mounting dimensions such that the centre of the platter to the centre of arm hole is approx 223mm plus or minus 2mm tolerance and the hole diameter for the arm is 24mm to 25 mm.

Please note that for Origin Live Silver, Encounter and Illustrious tonearms - do not adjust bearing tightness - this is carefully set at factory - it may seem that there is “play” in the bearings - this is **deliberate** and must be left alone or degradation will result - it is not actually play in the bearing races but careful bearing fitting to allow a loose bearing fit thus “floating” the arm rather than rigidly coupling it to the deck.

NOTE

If you are fitting a Rega or Origin Live Arm to the Aurora, Aurora Gold, Resolution, Resolution Classic or Sovereign turntables you will only need the sliding aluminium sleeve VTA adjuster, which is clamped in place by the single grub in the arm base. None of the large washers or the large nut, if they have been supplied, are needed.

VTA (vertical tracking adjustment)

To allow the cartridge needle to track at the correct angle it is important that the base of the arm is at the correct height in relation to the platter.

For Rega arms, the OL1 series and Silver arm - Usually the optimum setting is such that the TOP edge of the arm is parallel with the surface of a FLAT record – you can use a piece of card with parallel lines drawn on it to check this once the cartridge is fitted.

For the Encounter, Illustrious and Conqueror arms – the centre line of the tapered arm tube should be parallel with the surface of a FLAT record. You can use the template supplied to help judge this.

It is always best to experiment with vta height by varying it and listening to the results till you have found the optimum position.

Most cartridges have a height of 17mm and if this is the case, then the base of the arm should rest approximately 31mm below the top of the platter surface. If your cartridge height is different you can work out where the base of the arm should be from the preceding figures.

Using the Origin Live VTA sliding adjuster

Do not fit a threaded VTA adjuster (supplied with some arms – this is a large knurled disc that can thread onto the arm base). Ensure that the Aluminium sleeve (this **IS** the VTA sliding adjuster) is the right way up with the recess on the top side. This ensures that the arm goes all the way down into the sleeve. Place the arm in the aluminium sleeve and then clamp it in position via the set screw in the side of the VTA housing (i.e the sleeve is forced in to grip the arm’s threaded base). You do not need the Rega nut on the base of the arm. Only tighten the set screw sufficiently to clamp the arm firmly in position – over-tightening can make the arm sound bright.

Fit the arm cable clip

Fasten the arm cable in position with a nut & bolt through the cable clip. This should be supported by a cable clip screwed into position underneath the plinth - leave a slight droop on it so that it isn’t “tight”. The clip fastens to the underside of the plinth outer ring using the hole near the rear foot. This again is helpful to “earth” vibration in the cable. (Please note that the occasional rewired arm can make a slight “rustling” noise through the speakers when it is lifted across the record. This should not be a cause for concern as it is only caused by microphony of the internal litz cable - under normal playing conditions this is inaudible. The earth lead should be connected to the earth of your pre-amplifier or amplifier. This earth lead is best separated slightly from the arm signal leads so do not wind it around them for best performance. Avoid pulling the external wires at the base of the Silver arms as they are not indestructible and can become detached if excessive force is used to manipulate them.

ARM & CARTRIDGE SET UP

Fit the cartridge (if not fitted already)

Fit the cartridge to the arm using an alignment gauge and ensure the headshell wires are bent so that they are clear of the record surface. If you are not familiar with fitting cartridges then please read the section “Hi-Fi Cartridges – Setting up procedures”.

TRACKING FORCE

Set the tracking force to the manufacturer's recommendations using a stylus force gauge (stylus balance). On all modified arms, Silver, Encounter Illustrious and Conqueror set the tracking force by sliding the counterweight along the rear stub until the required tracking force is attained, then clamp up the grub screw in the side. When adjusting the counterweight, set it so that the Allen bolt is at the side of the arm (not at the top) see figure "Rear end view of counterweight". You will need a stylus force gauge to measure the force underneath the cartridge tip.

HINT - In conducting this operation it helps to just lightly "nip" the allen bolt in the side of the counterweight onto the stub – this way the counterweight has a little friction to hold it in position as you slide it backwards and forwards. Once you have set the tracking force correctly you can firmly tighten the allen bolt in the counterweight to secure it tightly to the rear stub then check that the tracking force is still correct after tightening.

On the OL1 tonearm which has not been modified (i.e it has a plastic rear stub with spiral groove) – You should turn the counterweight till the arm balances level – once this is accomplished you can then set the tracking force by turning the counterweight – half a turn = 1 gram.

REAR END VIEW OF COUNTERWEIGHT AND ARM MOUNTING

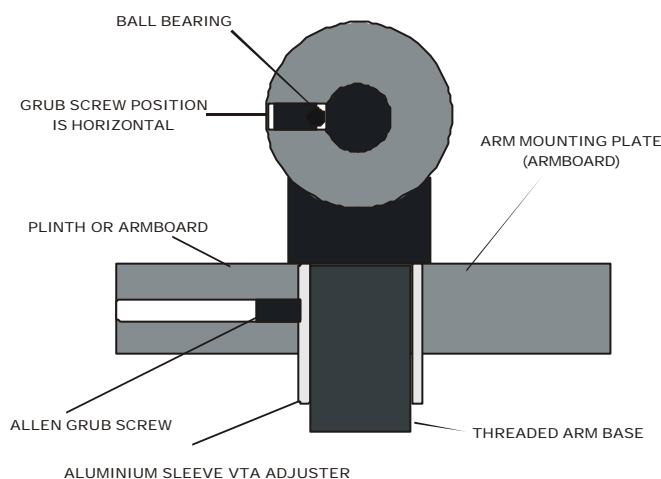

Use of Stylus force gauge

Most stylus force gauges work on the same principle as a set of scales or balances. For example with the Ortofon Stylus Force Gauge, first place the stylus on the inscribed or graduated portion of the scales. Then try the stylus at different points until you find the point where the beam "balances" freely in a roughly level position. You then read the force that is being exerted – (1 gram = 10 mN if the scale is in mN). From this number you can assess whether you need to increase the tracking force or vice-versa. Move the tonearm counterweight accordingly and re-measure the tracking force. Repeat this procedure until the correct tracking force is obtained. The Shure stylus force gauge works slightly differently so follow the instructions that come with the gauge.

SIDE BIAS FORCE

Once the tracking force has been set you can set the sliding control for tracking bias - This should be set to a value of approximately 1 or less due to the fact that the bias adjustments on Rega arms and similar arms tend to under-read the true value of side force produced. . The settings you read on the Rega, OL1 or Silver arms are not always dead accurate so it may be worthwhile to fine tune the setting using the following method. Find a test record or a record with approx 10mm of blank vinyl between the end of the lead out groove and the record label. Place the stylus needle on the blank uncut vinyl and see whether the needle skates inwards towards the centre of the record or outwards. You are aiming to achieve a situation where the needle drifts *slowly* towards the centre of the record so adjust the side bias until this state is reached.

As the stylus tracks across a record it experiences forces that tend to push it towards the centre of the record. To counteract this force the arm is best set up with an approximately equal and opposite force called the "side bias"

On Rega, OL1 and Silver arms the side bias force is set using the small sliding knob located beside the lift lower lever.

On the Encounter, Illustrious and Conqueror arms – Carefully twist the wire loop to the correct angle relative to the arm base – you can use the enclosed plan view of the arm to do this – the angle only needs to be approximate – the wire loop is held in place by a set screw at it's base – this can be retightened if necessary using the 1.5mm allen key supplied.

Carefully unpack the 2 balls and joining thread. Set up the 2 balls and thread as shown in photo below. The side bias force is set using the ball which slides along the silver shaft protruding from the rear of the arm yoke (beside the counterweight) - see photo below. This ball is clamped in position using a set screw in the ball with 1.5mm allen key. Thread the thin nylon filament line through the small gap of the wire "eye" to allow the ball weight to hang freely. The adjustment ball is initially set at just under three-quarters of the way out along the silver rod – this is approx the correct position for most cartridges. If you wish to increase the side bias force then unclamp the ball using a 1.5mm Allen key and the ball further outwards. To decrease the side force move the ball inwards. Once you have finalised the correct position re-clamp the ball in position.



Set the VTA (vertical tracking adjustment)

To allow the cartridge needle to track at the correct angle it is necessary that the base of the arm is at the correct height in relation to the platter. Usually the optimum setting is such that the TOP edge of the arm is parallel with the surface of a FLAT record – you can use a piece of card with parallel lines drawn on it to check this. Place the cartridge on the record with the deck switched off. Hold the card edge onto the record in a position alongside the arm and see whether the top edge of the arm is parallel.. Raise or lower the base of the arm till you achieve parallel position. Most cartridges have a height of 17mm. If this is the case, the base of the arm should rest approximately 31mm below the top of the platter surface –see diagram “cross-section of sub-chassis”.

It is worth experimenting with VTA adjustment. Slightly raise or lower the arm and then listen - if the sound is relatively bright then the arm is too high, if it is relatively dull and bass heavy then the arm is too low.

- **If you have no VTA adjuster** Raise and lower the arm by fitting spacing washers under the arm. Alternatively you can raise or lower the height of the platter – this is easily accomplished by removing the platter & sub-platter to re-set the height of the threaded bearing house (see “diagram showing threaded bearing house arrangement”).
- **If you have the threaded VTA adjuster** Raise and lower the arm by rotating the VTA adjuster. If you find your arm is too high in relation to the platter with the VTA adjuster set to give the arm it's lowest position then you need to raise the height of the platter a few millimetres – this is easily accomplished by removing the platter & sub-platter to re-set the height of the threaded bearing house (see “diagram showing threaded bearing house arrangement”).
- **If you have the Origin Live VTA sliding adjuster** – Raise and lower the arm in the aluminium sleeve and then clamp it in position via the set screw in the side of the VTA housing (i.e the sleeve is forced in to grip the arm's threaded base). You do not need the Rega nut on the base of the arm. Only tighten the set screw just sufficiently to clamp the arm in position – over-tightening can make the arm sound relatively bright.

Set the arm fastening tightness

It is best to experiment with the tightness of the large Rega base nut (if fitted) by listening to music. This may seem laborious but you will be richly rewarded as this adjustment is CRITICAL for performance. The mistake is often made of over tightening this nut with the result that the music is deadened.

Warranty

We guarantee arms supplied by ourselves to be free from fault for 2 years and will undertake to correct any faults providing the arm has not been modified by any party other than ourselves and has not received maltreatment of any kind. Our OEM arms and modifications are not guaranteed by Rega so in the event of a warranty claim you should contact ourselves rather than Rega.

Notes

A detailed description of Cartridge set up and care is included in the end sections of this manual.

Please note that the occasional rewired arm can make a slight “rustling” noise through the speakers when it is lifted across the record. This should not be a cause for concern as it is only caused by microphony of the internal litz cable - under normal playing conditions this is inaudible.

Check that the arm can move freely across the whole record – if there is a “catch” then it is almost certain that the curved arm rest is fouling on the yoke – simply rotate the arm rest till it no longer fouls – this can be carried out without loosening the arm rest grub screw.

On the Illustrious and encounter tone-arms you can get a “gripping” action with the arm rest clip if you rotate it very slightly so that it is at an angle to the arm (not too much or you might get wear on the arm).

The earth lead should be connected to the earth of your pre-amplifier or amplifier. This earth lead is best separated slightly from the arm signal leads so do not wind it around them for best performance.

Now that all the hard work is over you can settle back and hear the results - we wish you many hours of enjoyable music and rediscovering your record collection.

You can increase the height of the lift / lower arm rest by loosening the small allen screw in the side of the curved arm rest and raising it slightly – finish by retightening it in position.

The sound of new arms and rewires will improve significantly over the first 2 weeks as items “bed in” and arm wires burn in.

Fit the cartridge to the arm using an alignment gauge and ensure the headshell wires are bent so that they are clear of the record surface. Ensure that the bias adjustment slider is set to zero. Set the tracking force to the manufacturer’s recommendations using a stylus force gauge (stylus balance). When tightening the counterweight, set it so that the Allen bolt is at the side of the arm (not at the top) see figure below and tighten firmly - check tracking force is still correct after tightening.

It is worth experimenting with VTA adjustment if you can. Slightly raise and lower the arm and then listen - if the sound is bright then the arm is too high, if it is dull and bass heavy then the arm is too low.

We guarantee arms to be free from fault for 2 years and will undertake to correct any faults providing the arm has not been modified by any party other than ourselves and has not received maltreatment of any kind.

NOTE: The Ortofon stylus force gauge works on the same principle as a set of scales or balances. First, place the stylus on the inscribed line on the white portion of the scales. Then try the stylus at different points along the line until you find the point where the white plastic beam “balances” freely in a roughly level position. You then read the force that is being exerted - 1gram = 10 mN on the numbered scale, . From this number you can assess whether you need to increase the tracking force or vica-versa. Move the tonearm counterweight accordingly and re-measure the tracking force. Repeat this procedure until the correct tracking force is obtained.

A detailed description of Cartridge set up and care is included in the end sections of this manual.

Hi-Fi cartridges - set-up procedures

INTRODUCTION

General comments

As we supply most makes of hi-fi cartridge we get asked questions from time to time about various issues regarding set up and care. To help newcomers to this area we have published the following notes. These guidelines are of a general nature - we publish them only to be of help and although widely accepted they are not formally authoritative - we cannot accept liability if you choose to use them and neither do we encourage the time consuming occupation of answering queries surrounding the procedures outlined - these are best referred to the manufacturer of your specific hi-fi cartridge.

For those new or inexperienced to fitting hi-fi cartridges we would state that this is NOT difficult and much of the detail and perfectionism outlined below is for those who like to experiment. We ourselves do not normally check azimuth, or vary tracking forces from the manufacturers recommendations - neither would we worry if the arm was up to 3mm away from the recommended distance from the spindle - although all these details are audible they are generally of a fairly low order, although tracking force and VTA are worth trying should you feel anything is lacking. If things seem complicated we would encourage you not to be put off as it all becomes clear once you get started.

Before fine-tuning the set up as described below you should allow the cartridge to "run in" properly - at least 40 hours for some cartridges.

Importance of cartridge set up

Hi-Fi cartridges travel like a bobsleigh through the grooves of a record only a few thousandths of an inch wide. You hear groove displacements of the order of a few millionths. (That's like splitting a hair into one thousand pieces.) Every bit of motion or vibration allowed at this level can be heard enormously amplified through your speakers. For this reason it is good to set up the turntable and arm correctly so that the audio cartridge can do it's job properly. For instance a turntable out of level can produce side forces on the pickup cartridge tip that will wear it more on one side than the other as well as have a slightly degrading effect on the wear of your records.

Levelness

When a turntable goes out of level, the platter bearing performance and the arm's dynamics, specifically anti-skate, are negatively affected. So be sure your turntable platter and tonearm mounting board are level - use a spirit level. If the platter is out of level, first adjust the surface that the deck stands on. The suspension (in the case of a suspended sub-chassis design) may also need levelling if it has subsided over time.

Hi-fi cartridges alignment

Alignment for hi-fi cartridges needs to be optimised in three different planes. However, it cannot be perfect in all three planes, so it must be optimised for an overall best balance or compromise. The final authority should always be your ears and preferably over an extended period of listening time. Bear in mind that each record is cut slightly differently. Here again, optimise for an overall balance of good sound over a wide range of records. The three alignment planes are as follows. (Please note that it is the stylus, not the cartridge that is being aligned.)

Lateral tracking angle

Viewed from above, the hi-fi cartridges arcing movement across the record must maintain the stylus in the same relation to the groove as that of the cutting stylus's straight-line tracking; this is Lateral Tracking Angle, or Tangency. Apart from linear tracking arms this is always a matter of the best compromise.

Azimuth

Viewed from head on, the stylus must be perpendicular in the groove so as not to favour one groove wall, and therefore one channel, over the other wall/channel; this is Azimuth.

Vertical tracking angle (VTA)

Viewed from the side, the stylus must sit correctly in the groove, at the same angle as the original cutter; this is Vertical Tracking/Stylus Rake Angle. VTA, however, varies from record to record. Therefore, this alignment must be set by ear, even more than is the case with the other adjustments).

Hi-Fi cartridge aligning tools

Tools required are an alignment gauge, a tracking force gauge, a FLAT record, a screwdriver or Allen keys of the right size (usually 2mm), a good light may also be helpful. Small needle-nose pliers and a magnifying glass all help. It also helps to have the hi-fi news test record. Treat the arm with care, as some parts are fragile. To this end ensure that tightening of any bolts is carried out gently and without causing undue strain.

Check hi-fi cartridge clip connections and mounting

Tonearm wiring uses a standard colour code for left channel (L) and right channel (R) and polarity. Coding is as follows: White = L Hot, Blue = L Ground, Red = R Hot, and Green = R Ground. If the cartridge pins aren't colour-coded the same way, they will have letter identifications next to them. Make sure that the arm's wires, wire clips, and solder joints are in very good condition. At minimum, clean the contact between cartridge pins and wire clips by removing and replacing each clip. Holding the clips with needle-nose pliers can make this easier, but be careful that you don't strain the wires where they join the clip. Check the clips for a proper fit on the cartridge pins, and adjust them if necessary. "Proper" means snug but not tight. To check clip size, hold the cartridge tail-up close to the head wires, grasp a clip firmly right behind its tubular part with the tweezers, line it up with the cartridge pin, and press. If it does not slide on with moderate force, the clip needs opening-up. If it slides on easily but flops around when attached, it needs tightening. Sizing is the operation most likely to detach a clip. The trick is to avoid bending the wire at its attachment point or putting too much tension on it. To avoid either, always hold the clip with its wire slightly slack-looped behind it while adjusting. For opening a clip, hold it firmly with the tweezers or needle-noses, right behind its tubular section, and press the tip of the jeweller's screwdriver into the open end of its longitudinal slot until you see this widen very slightly. (Here's where you'll probably need the headband magnifier or reading glasses.) You're dealing with thousandths of an inch here, so a barely visible spreading may be all that's needed. Try it for fit, and repeat until it does. For tightening a clip, press a toothpick inside it as far as it will go, then use the needle-nose pliers to gently squeeze together the sides of the clip near its free end, while watching the slot for any change. (Attempting to squeeze a clip without the toothpick inside it will flatten its sides.) Try it for size, and squeeze again if necessary until the fit is correct. When it is, close up the middle section of the tube to match the end

Cartridge mounting screws (usually 2.5mm Allen bolts) should be tight. Steel Allen bolts are the best for mounting hi-fi cartridges - aluminium or brass are OK but difficult to tighten up hard (as they should be).

SETTING UP HI-FI CARTRIDGES

Mounting

Mount the hi-fi cartridge in the headshell if this is not done already. This is best done with the hi-fi cartridge stylus guard in place but it may be necessary to remove it during at least one phase of the installation. If you do, replace it as soon as possible. Be especially careful when the stylus guard is off, as many MC cartridges have a strong magnetic field at the base of the cantilever. If this attracts the tip of a steel-bladed screwdriver, it can destroy the stylus - there is no hope of resisting it. The best precaution is to keep the screwdriver well away from the cantilever, use a nonferrous screwdriver, or keep the stylus guard on when you're using the screwdriver near it. The other main hazard is children so don't forget to warn prying fingers.

The headshell screws should be finger-tightened just enough that the cartridge cannot fall off but still loose enough that the cartridge is easily moved around. Work whenever possible with the stylus's safety cap in place. Set tracking force at nominal, then does the tangency alignment procedures, then the azimuth. Do not deviate from this sequence as each step affects the subsequent one — change the order and the set-up will be wrong.

Tracking Force

This adjustment is carried out on the counterbalance weight of the tonearm or spring dial if one is in place. At this point, use your tracking force gauge and setting tracking force according to your cartridge instructions — final adjustment will be done later by ear.

If you do not have a tracking force gauge, but the arm does have a calibrated counterweight, defeat the arm's anti-skate mechanism or set it to zero. Set the counterweight so the arm is level and balanced. Be very careful of the unprotected stylus — you cannot do this with its safety cap in place. Once the arm is balanced, lock it in its cradle and, using the calibrated counterweight, set the tracking force according to your cartridge's recommended weight.

Tangency Alignment

(Lateral tracking angle) - Follow the manufacturer's literature and the dictates of your alignment gauge — different gauges use slightly different methods. As you square up the hi-fi cartridge body with the gauge's markings, be sure that the cartridge sides are square or your alignment will be wrong. When all adjustments are correct, carefully tighten down the hi-fi cartridge mounting screws. Keeping a firm grip on hi-fi cartridge and headshell together so nothing shifts, delicately tighten each screw down a turn or so, and then repeat until tight. Tightening down one screw all the way before tightening the others is almost certain to twist the cartridge out of alignment. However careful you've been, always check the alignment again after tightening.

Vertical Tracking Angle (VTA)

Unless your tonearm has a special VTA adjuster, adjusting arm height is usually carried out with the use of spacing washers (as with Rega arms). In arms with a pillar / collar type vta adjuster it helps to put pencil or pen marks on the pillar to keep track of various heights. See your tonearm manual for its recommendations on adjusting arm pillar height. The best approach is to tune-in VTA gradually by listening to music. You know the arm needs to be lowered at the arm pillar when the overall sound is hard and bright, with thin bass or no deep bass, edgy highs, and harsh midrange (of course, this could also be tracking force which is too light). Distortion obscures low level details between the musical; notes so dynamic range is reduced. Transient attacks may be too sharp. Raise the arm when the sound is dull and damped, the highs rolled off, the lows muddy and lacking definition, and transient attacks are dull. Mind you, this sounds an awful lot like the effects of changes in tracking force (too light is edgy, too heavy is heavy and dull). They are different sounding but hard to explain. Start with the arm a little low and very gradually raise it, first to where it is parallel to the record, and then so the back of the cartridge is tilting up. Keep track of your settings so you can return to the one you like best where everything snaps into focus. The range of adjustments can be quite broad, as much as 3/4" or even more (at the arm pivot). Play with the full range so you know what it sounds like and don't be diffident.

Antiskate Force (pivoting arms only)

This applies an opposing, balancing force to the natural inward drag of a pivoting arm while playing. Left uncontrolled, the stylus would push up against the inner groove wall, causing distortion both from mistracking and a cantilever skewed in relation to the cartridge generator. To set, lower the stylus down near the label of a record with a wide run-out to it. Increase antiskate until the arm starts to slowly drift outward, away from the label. Again, this should be finalized by ear as you listen to music. If image placement is a little off-centre, or if things don't seem to be locked in solidly, experiment with antiskate. Also, watch the stylus when you set it into a groove. Does it move to the right or left relative to the cartridge body? This indicates too much or too little antiskating.

Fine Tuning

You now have three adjustments approximated. Tracking force, VTA, and azimuth. It's a matter of reiteration to optimise the sound. The change in sound with each of these individual adjustments can be similar. It's therefore necessary, in optimising all three, to experimentally move from one type of adjustments to the next, then to the next, in order to balance the optimisation for all three. It's helpful to listen to female vocals as you proceed. Firstly try deviating from the cartridges recommended tracking force by small increments - about 0.2 of a gram deviation above and below the manufacturer's basic recommendations. Don't worry about record damage from heavy tracking as most record damage is actually caused by mistracking in the middle-to-high frequencies with too little tracking force rather than with too heavy. If you're getting mistracking at the low (lightest) end of the range and yet the low range is generally sounding the best (and on moderate signals, not heavy passages), then chances are you have either a dirty stylus, a bad record, an accumulation of crud in your

cartridge, or a cartridge that's getting old. Changes in tracking force can change how you want VTA and azimuth adjusted. If azimuth was initially adjusted by ear, experiment with it.

Proper care and maintenance of Hi-Fi cartridges & records

CARE OF HI-FI CARTRIDGES

Replace your cartridge when due - hi-fi cartridges have a lifespan for their cantilever suspensions and stylus needles. This will vary from manufacturer and type of cartridge as well as other factors like the cleanliness of your records and the care you take of the cartridge. It is wise to enquire on the expected life of your cartridge to the manufacturer, so that when the time comes it is replaced accordingly - most importantly this will preserve your records as well as enable you to enjoy the best performance.

If there is a build-up of dust and dirt where the needle enters the cartridge body you should use a small soft brush to brush the debris out. Always brush from the direction of the cantilever to the stylus or you may do damage.

Care of stylus - One well known method of cleaning styli is the Linn green stuff which is a very fine abrasive paper - this may be OK on some cartridges which do not have fine stylus tips and fragile cantilever mechanisms. However there is a danger of causing fractures or chips in your diamond stylus on certain fine line tips. This method can also strain the cantilever mechanism.

There are a number of fluids on the market that increase stylus life and help to clean grunge from the needle - a word of caution though - some of these can loosen the stylus glue on the cantilever over time - some fluids can also attack the cantilever or coil material itself or harden the suspension - consult your cartridge manufacturer over this. One key factor is to use the liquid very sparingly on a cotton bud such that it is just damp (not running with fluid) - this minimises the fluid, which can run up inside the cartridge.

RECORD CARE AND CLEANING

The stylus itself does a pretty good job of cleaning the grooves and should itself therefore be kept clean. The proprietary brushes etc. for cleaning records will often do little more than brush dirt deeper into the record grooves and are best avoided if possible. Also keep records in high quality non-scratch record sleeves - preferably good ones.

A record-cleaning machine is really the only answer for cleaning records properly as they suck out the debris and dust in the record grooves using a powerful vacuum. Tests using a microscope prove that this does the job with 100% success. The performance improvement is also very noticeable when it comes to even new records being played. We supply and highly recommend the Moth record cleaning machine as this is very effective from personal experience and comes with many glowing endorsements – see our web site for details and reviews.

