



Instruction Manual

DC Motor Kit For Turntables



Contents

PG.3 Introduction

PG.3 Packing List

PG.4 Installing The Kit

PG.4 Motor Installation

PG.4 Correct Belt Tension

PG.5 Connecting Power Supply

PG.5 Upgrade Transformer

PG.6 Setting Motor Speed

PG.6-7 Notes

PG.8 Trouble Shooting

PG.9 Example Kit Fitting (LP12)

Introduction

Congratulations on choosing your Origin Live DC motor kit. You can now look forward to hearing dramatic performance improvements in your system.

To achieve the full level of performance it is critical that this instruction manual is followed and read fully.

Installing the motor will be relatively easy for some decks and more challenging for others. If at first things appear difficult, give yourself time to think clearly and you will invariably find ways of accomplishing your objective. Most of the installation demands little expertise – if you think anything is beyond your capability then you can either ask a friendly dealer to do the job for a small fee or get a friend to do it.

These instructions are written to cater for those new to turntables. Some sections may therefore appear lengthy, as they need to address all potential questions and levels of expertise. When reading the instructions refer to the various diagrams for part names and clarity.

The motor kit can take as little as 30 minutes to install depending on your deck and expertise. The DC regulator electronics will initially encounter speed drift when first started (if they have not been run in) and so **may need at least 4 hours to run in before the speed can be finally set with accuracy.** We wish you an enjoyable time not only in setting up but most of all in the end result.

Packing List

When you unpack the kit, check that you have all the parts listed in the pack list.

- External Control Box
- Transformer or Wallwart
- DC Motor / Pulley
- 2x no 6 ½ Screws / 1 Small Cable Clip
- (For Linn Turntables Only) 4 x M6 Brass Washers / 2mm Allen Key / Switch Cover Plate

Options

- Round Transformer - Medium size fully balanced transformer
- Upgrade, large transformer purpose built for the DC motor kit
- Ultra control box - components in the circuit are upgraded to the highest possible quality and specification along with precision tuning. The circuit design also includes added sophistication.

Paperwork

- Motor Kit Instructions
- Strobe Card

Installing The Kit

Disconnect Old Supply

Unplug the deck from the mains supply for safety reasons and before doing any work allow capacitors to discharge for 45 minutes – especially on the Linn which can give a dangerous discharge from it's Valhalla board. Do not remove a base board cover before this period is over as there is danger of lethal electric shock. You MUST also remove the mains plug at this stage to avoid any possibility of someone plugging it in at a later stage. You will not need the old power supply any more, so it can either be detached entirely or simply left in place for quick reversal of this modification.

Motor Installation

Fitting the motor is fairly self-explanatory but will vary slightly from deck to deck. If the motor body is too long you may need to raise the height of your deck using higher feet.

The motor is normally supplied with a “tall” pulley but you may need a shorter pulley (10mm less in height) – Please contact us if this is case. The motor sounds best supported by only 1 bolt.

You can tension the belt by pivoting the motor plate about the bolt and relying on the bolt friction to hold the motor in position. You should aim to have at least the belt tension required to

prevent the platter running slow or incurring speed variation due to slippage. To this end it is best to have it relatively tight when setting the motor speed and then slacken it off fractionally without any loss in sound quality once you know the speed is correct. There will be an optimum tension although it is not always easy to tell by listening and the tension is not that critical.

Please see Fitting Power Supply Ip12 for further information.

Correct Belt Tension

To set correct belt tension finally, lift the belt off the pulley and let it lose it's tension almost completely whilst still holding it gently - With no tension whatsoever in the belt it should be approx 7mm off the nearside of the motor pulley (flange edge) as per diagram below. Move the pod till the pulley is this distance from the belt, then stretch the belt to fit over the pulley.

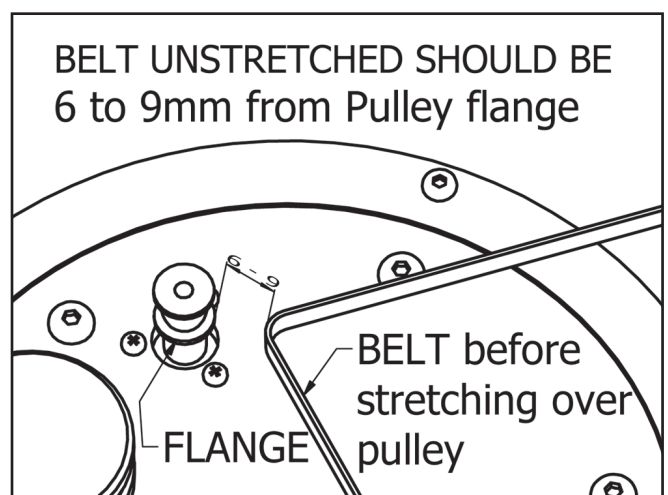

You can tension the belt by pivoting the motor plate about the bolt and relying on the bolt friction to hold the motor in position. You should aim to have at least the belt tension required to prevent the platter running slow or incurring speed variation due to slippage. To this end it is best to have it relatively tight when setting the motor speed and then slacken it off fractionally without any loss in sound quality once you know the speed is correct. There will be an optimum tension although it is not always easy to tell by listening and the tension is not that critical.

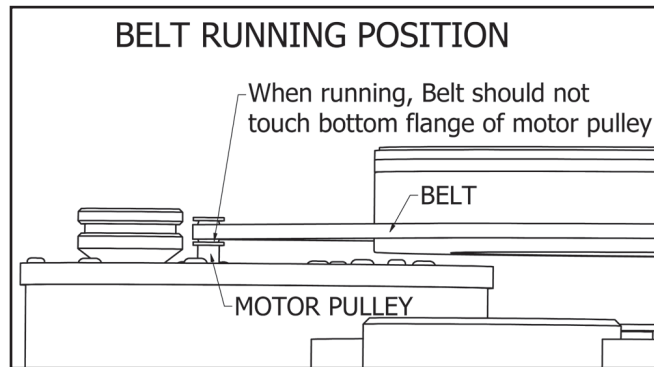

Connecting Power Supply

Plug the motor and power supply plugs into the matching sockets at the rear of the control box.

1. Plug the smaller male DC connector from the motor into the left hand of the two holes at the back of the control box Page 4 (see diagram).
2. Plug the male DC connector from the transformer (low voltage input) into the right hand socket (when looking at the back of the box) another way of describe it is the socket directly behind the LED.
3. You will know that the motor kit is connected up correctly when the LED comes on (This light will remain lit all the time that the motor kit is plugged in at the mains supply). The location of the control box should preferably be kept away from strong electromagnetic fields such as those generated by transformers, amplifiers, power supplies etc.

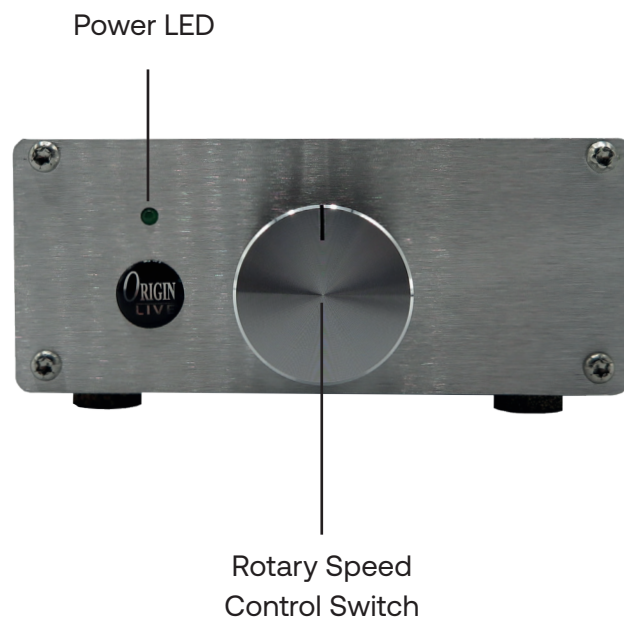

Upgrade Transformer

To upgrade to the Origin Live Upgrade transformer you simply need to unplug your existing transformer (mains connection) and plug in the upgrade transformer.

Note: You will need to set/reset the speed if you are changing up to the upgrade transformer see setting speed below

Setting Motor Speed

Please note: In the first 4 hours of use from starting up the motor, the speed tends to drift but then settles down fairly permanently. To burn in the regulator board components we recommend at least 4 hours of running the motor at 33 rpm (approx) before you accurately set the speed.

The thin output wires from the transformer only carry 8 volts and are safe to handle. **Voltages inside the transformer are dangerous so the transformer case should not be unscrewed or opened.**

The switch box is designed such that when the rotary switch on the front of the control box is turned fully anti-clockwise the motor is off. One click of the switch clockwise is 33.3 rpm and the second click clockwise is 45rpm.

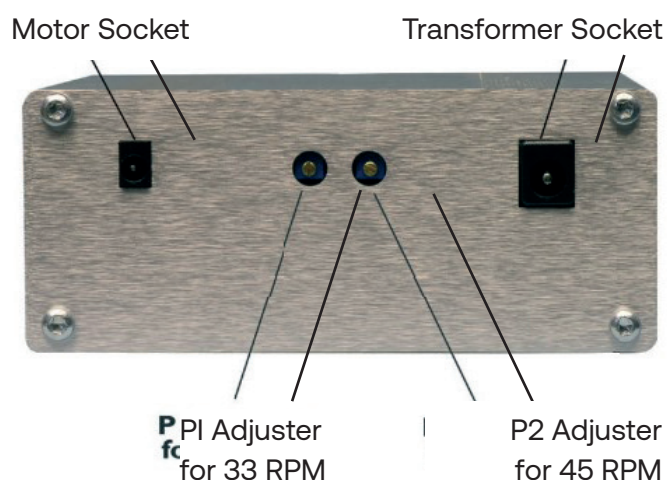

Adjust the motor speed as follows: using a small flat blade screwdriver turn the screws of the 25 turn Trimmer resistors P1 and P2 on the regulator board. P1 is for the 1st speed 33 rpm and P2 45 rpm. To increase speed, turn the screws clockwise. The pre-set screw will not fall out and may need a fair number of turns to set the correct speed so keep turning until the speed changes. If the screw reaches the end of it's travel you can usually hear a faint clicking.

Please note: The speed should only be checked with the cartridge dragging on a centre track of a record as the drag affects speed setting slightly.

Reading The Strobe

Place the strobe disc on the record to be played. Play the record and watch the relevant ring on the disc. Adjust the speed until marks on the ring appear stationary while the record is rotating. It sometimes helps to stare at infinity whilst doing this as the marks become easier to see. You can see the strobe effect in florescent light although an ordinary bulb held about 2 feet from the strobe disc will also work fine. The bulb flickers at 50 Hz in the EEC and 60 Hz in the USA. You can purchase bayonet fitting florescent bulbs to fit normal lamps. Try to shut out daylight when carrying out speed setting.

Note A: P1 is the left hand adjuster when looking at the rear and P2 is on the right.

Note B: You cannot use many modern LED lights or high frequency fluorescents because these bulbs use a modified supply which is not 50 or 60 Hz as the mains is.

Rotate the switch knob on the control box clockwise to the first click i.e. 33 rpm setting.

Set P1 so that the platter turns at 33.3rpm. When setting the speed, place the arm on the centre track of a record so that the cartridge is tracking the grooves. This ensures that the drag of the cartridge is taken into account. Speed variations of up to plus or minus 1% are quite common on decks and the DC motor is capable of plus or

minus 0.1% accuracy. Use the strobe disc provided to set the speed (instructions are on the card). However if you have problems using the strobe card, then count the rpm using the following method. Counting the 33.3 revs per minute is best accomplished by placing a small piece of sticky tape on the perimeter of the platter and then counting 100 revolutions. 33.3 rpm is exactly 100 revolutions completed in 3 minutes. To save time in the early stages it is easiest to count 50 revs in 1 minute 30 seconds (or 25 revs in 45 seconds) and save the 100 count for the final check.

Please note the following points when setting the speed. Firstly all the figures below are based on setting the speed on the deck using the centre track and letting the deck play for a good 5 minutes beforehand with the stylus on the record so that the whole system has settled down. The regulators seem to take about 5 minutes to warm up, so speed is about 2mins 58 seconds for 100 revolutions when the system starts from cold. In other words it is $2/180 \times 100 = 1\%$ fast when started from cold. Speed variation with the DC motor varies minutely depending on the track played and cut of record.

Click the rotary switch to the 2nd click clockwise and set P2 so that the platter rotates at 45 or 78 rpm (if you wish) using the same procedure as outlined above. The DC motors emit a slight noise to begin with and are never completely silent in comparison to a/c motors. This is due to their precious metal brushes. Having said this they still sound a great deal better in performance terms. Allow approx a 4 hours running in period then reset the motor speed. The motor should then be run for approx 2 days under load (i.e. turning the platter) to free it up from vibration and to “bed in” the bearings.

Like most other turntable manufacturers we recommend that you leave the turntable running between changing records as this reduces the belt wear that occurs with constant stopping and starting.

Note A: Do not use the power supply for anything other than the DC motor or the power supply may be irreparably damaged and you could also damage the equipment you are plugging it into.

Note B: The circuit will take around 8 hours to run in and sound its best.

Trouble Shooting

The speed stability of your deck should be excellent once everything has settled down in a listening session i.e.:

- The power supply and switch box have been left plugged in on standby for 15 minutes
- The platter has been turning for 2 minutes
- The cartridge has been on the record for 30 seconds

Bear in mind that the ear detects when music is playing slightly slow much more easily than it detects it playing fast. For this reason most manufacturers set their decks to run slightly fast. You can expect a bit of speed variation when the motor is first switched on - it takes about 2 minutes to warm up properly and then the motor should run at its correct speed but only when the stylus is on the record.

It is highly preferable to keep the power supply plugged in at all times (unless you are away on holiday) because it takes a good 15 minutes to warm up from cold and run correctly. When in

Speed Variation Trouble Shooting

If there is significant speed variation then causes can be down to the following:

- Significant changes in room temperature (this affects decks which use thick, viscous oil in the bearings)
- Lack of oil in the bearing, check by adding oil
- Changed belt tension
- An oily belt / sub-platter, clean running surfaces
- Turntable out of level, this affects the main bearing friction
- After adjusting the tension of the 3 small Philips screws which hold the motor on you may need to re-adjust the speed as they affect motor tilt very slightly
- Check the sub-platter is not fouling on anything, on certain decks it can rub against one of the spring covers. It has also been known to “bottom” against the top of the bearing house, there should be about 1-3mm clearance between the top of the bearing house and the bottom of the sub-platter
- A dirty bearing that exhibits too much friction. The sub-platter should drift round effortlessly with the slightest of nudges and go on spinning. If you suspect the bearing friction to be a little high return, talk to the manufacturer
- A worn thrust bearing
- Transistors that have developed temperature instability

standby mode the control box draws a negligible current so you need not worry about your electricity bill.

If you keep switching the deck on and off you will get a little speed variation as it takes approx 2 minutes to warm up the circuit each time even if it's only switched off for 3 seconds. This is unavoidable although we have tried to design out the variation as much as possible.

If you measure the speed within 30 seconds of putting the needle on the record the speed will not be perfect as it takes a while to settle down.

Some people make the mistake of constantly watching the speed before the deck has settled down and the needle has been on the record for a good 2 minutes. Strokes are very accurate and the slightest speed variation is picked up. 0.03% variation is observable.

Excessive Motor Noise

The motor needs a run in time of around 2 - 4 days continuous running. They are sometimes a little noisy to start with. Most importantly you can "tune in" the motor to give minimum noise by slackening off all 3 mounting plate screws next to the pulley then tightening one screw in turn. Find out which screw reduces motor noise when lightly tightened and then adjust the other two to give minimum noise.

Please note that by adjusting these screws you effect the angle of the motor. If the belt touches the flanges at the top or bottom of the pulley then the motor is at too extreme an angle and you will need to re-adjust the bolts. The ideal is for a vertical pulley with the lowest noise level. If you get a knocking sound from the motor then slightly slacken off the three screws holding the motor to the top plate.

It may be necessary to use thread lock or similar to stop the screws vibrating loose. If it continues to be very noisy please get back to us and we may check it out. However bear in mind that the DC motor is never silent as a/c motors are - this

is because they rely on a higher grade of brush.

The other major potential source of noise is the motor vibrating against it's top plate and causing it to resonate. The solution is usually to slightly tighten the 3 small screws holding on the motor. This adjustment is fairly critical - if the 3 small screws are too tight then the motor whispers, too slack and the motor can vibrate against it's top plate.

If you have checked the above and are still having trouble please contact us making a note of the serial number on the back of the control box.

Example Fitting the Kit to an LP12

To fit the DC motor kit to the Linn is straightforward by carrying out the following steps. No drilling of the top-plate is required and the modifications are easily reversible should you ever wish to sell your Linn but retain the DC motor.

Unplug the deck from the mains supply for safety reasons and before doing any work allow the Valhulla capacitors to discharge for 45 minutes. Do not remove the baseboard cover before this period is over as there is danger of lethal electric shock. You MUST also remove the mains plug at this stage to avoid any possibility of someone plugging it in at a later stage. You will not need the Linn electronic power supply any more, so it can either be detached entirely or simply left in place for quick reversal of this modification. The LP12

will sound better if the Valhulla board is removed entirely due to the additional resonance it inputs to the plinth.

Unscrew the baseboard from the Linn - the screws, which hold on the 4 rubber feet and 2 others, usually hold it on.

Disconnect the 4 wires leading to the Linn motor (2 grey, 1 blue, 1 red) by slackening the screws holding them at the terminal block.

Unscrew the 2 slotted pan head screws that control the tilt of the Linn motor.

Unscrew the 2 black round headed Allen screws that hold on the Linn Motor - you may need to

slacken off the nuts underneath first. This will allow you to remove the Linn motor but be careful not to lose the 4 cone-shaped spacing washers that reside between the top of the motor and the bottom of the stainless steel top plate (see Fig 1).

It is also recommended to remove the belt guard as this can rub against the belt depending on how your Linn is adjusted.

Now fit the DC motor as shown in Fig 2 below using an original black round headed Allen bolt and nut plus the 2 brass washers supplied with the kit. The brass washers only serve as spacers - they are not designed fit directly under the bolt heads. The bolt only need to be "nipped" tight for best sound quality and the distance from centre of platter to motor pulley centre should be adjusted to approx 127- 129mm for correct belt

tension (start at 127).

There are 3 holes drilled in the DC motor top-plate to allow extra flexibility in positioning the motor as Linns differ slightly in dimensional set up. For tension see also notes on wiring the power supply. Now connect up the control box set the speed (see previous text) and enjoy!

Note: The plate can be attached using super glue. (If you wish you can remove the existing Linn on off switch and replace it with the Origin Live logo / brushed stainless steel plate supplied.)

FIG 1

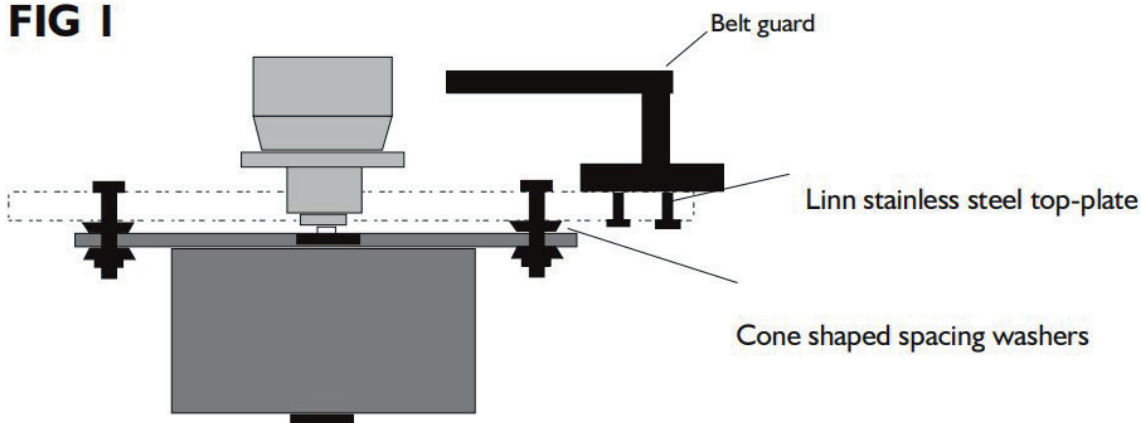

FIG 2

