

BUILDING THE ULTRA KIT

Instructions by Origin live ©



The Complete Ultra Turntable kit

VIEW OF TOP MINUS SUB-PLATTER AND PLATTER



VIEW OF ASSEMBLED KIT FROM UNDERSIDE

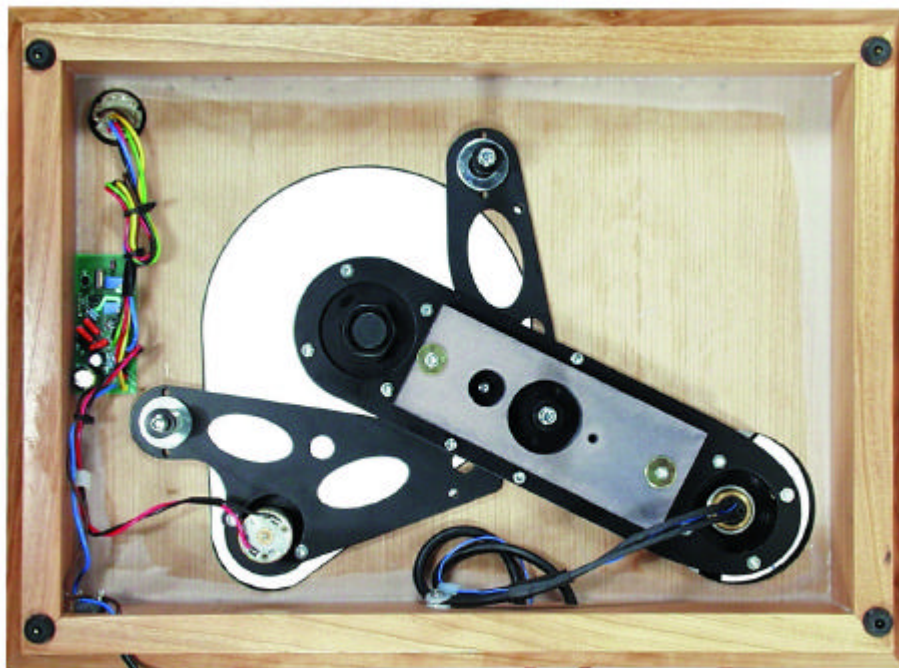

Contents

CONTENTS	3
List of Diagrams	4
INTRODUCTION (READ CAREFULLY)	5
PARTS LIST & TOOLS REQUIRED	6
Parts supplied	6
Tools you will need ideally	6
TURNTABLE ASSEMBLY	7
Preparation	7
Plinth and lid assembly	7
Fit the rubber feet	7
Fit the Lid	8
Fit the switch and dc regulator board to the plinth.	8
Fit the 3 threaded support bolts	9
Install the sub-chassis	9
Fit Bearing house	9
Fit the motor	10
Install Sub-chassis & Fit springs	10
Connect the motor wires	10
Install the arm	10
If you do not have a VTA adjuster	11
If you have the Origin live threaded VTA adjuster (which fits all decks)	11
If you have the Origin Live VTA sliding adjuster	11
Fit the arm cable	11
Fit the cartridge	11
Install the Sub-platter & Platter	11
Troubleshooting	12
SET UP OF MOTOR AND POWER SUPPLY	12
SET UP & MAINTENANCE OF TURNTABLE	12
Set up	12
Notes & Maintenance	12
Notes	12
Maintenance	12
SET UP OF TONEARMS	14
Final arm set up and notes	14
Fit the cartridge (if not fitted already)	14
Set tracking force & side force bias	14
Use of Stylus force guage	14
Set the VTA (vertical tracking adjustment)	14

Set the arm fastening tightness	15
Notes	15
HI-FI CARTIDGES - SETTING UP PROCEDURES	16
Introduction	16
General comments	16
Importance of cartridge set up	16
Levelness	16
Hi-Fi cartridges alignment	16
Hi-Fi cartridge aligning tools	17
Check hi-fi cartridge clip connections and mounting	17
Setting up hi-fi cartridges	17
Mounting	17
Tracking Force	17
Tangency Alignment	18
Vertical Tracking Angle (VTA)	18
Antiskate Force (pivoting arms only)	18
Fine Tuning	18
PROPER CARE AND MAINTENANCE OF HI-FI CARTRIDGES & RECORDS	19
Care of hi-fi cartridges	19
Record care and cleaning	19
LIST OF DIAGRAMS	
View of top minus sub-platter and platter	2
View of assembled kit from underside	2
Cross section of suspended sub-chassis	5
Diagram of Sub-chassis assembly	7
Diagram of lid assembly and rubber feet	7
Top view of wiring layout & connections	8
Diagram of support bolts and spring arrangement	9
Diagram showing bearing house fastening arrangement	9
Diagram showing spring positions	10
Rear end view of counterweight	15

Introduction (read carefully)

Congratulations on choosing the Origin Live Ultra turntable kit. You now have one of the finest sounding turntables available at any price - not only will it provide an extraordinary level of high performance but also reliability and low maintenance.

To achieve the full level of performance it is critical that this instruction manual is followed and read fully. There are aspects of this turntable which run contrary to what you may expect so before altering anything it is important to have fully read the manual or degradation will result. For example some people expect all bolts to be fully tightened but testing has shown this to have a significant degrading effect.

Building a turntable will be relatively easy for some and a challenge for others. If at first things appear difficult, give yourself time to think clearly and you will invariably find ways of accomplishing the objective. Most of the kit demands little expertise – if you think anything is beyond your capability then you can either ask a friendly dealer to do the job for a small fee or get a friend to do it.

These instructions are written to cater for everyone from beginners to experts in kit assembly and vinyl replay. Some sections may therefore appear lengthy as they need to cater for all potential questions and levels of expertise. When reading the instructions refer to the various diagrams for part names and clarity.

The kit will take between 1 to 4 hours to assemble depending on your expertise. The dc regulator electronics initially encounter speed drift when first started and so will need at least 4 hours to run in before the speed can be finally set with accuracy.

We wish you an enjoyable time not only in the building but most of all in the end result.

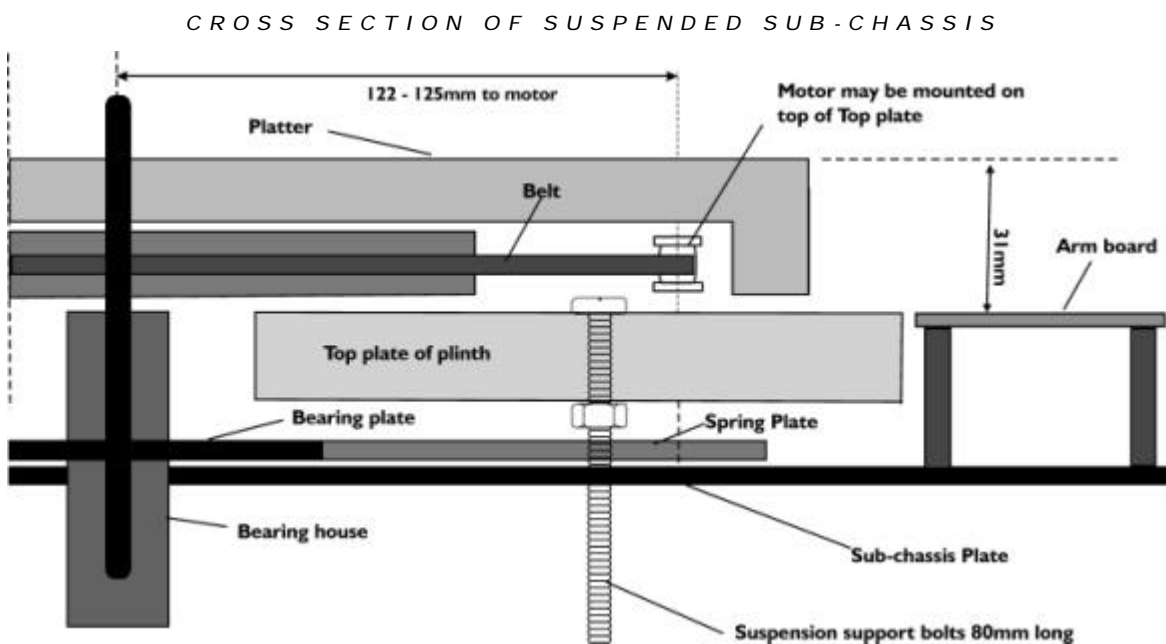

Parts list & tools required

PARTS SUPPLIED

- Ultra plinth, 4 small rubber feet and 4 nails
- Lid, (usually fitted 2 off Lid hinges bottom & 2 top, 4 off M4 x 10mm bolts, 4 off M4 nuts, 4 off M4 brass washers).
- Bag – Belt, 2 off cable clips (small & large), 6 off no 6 x 3/4" screws, Bag - 3 springs / 3 long M5 bolts / 3 spring seats / 3 rubber washers / 6 off M5 brass washers / 9 off M5 serrated washers / 6 off M5 nuts
- Platter
- Sub-platter
- Main bearing house on sub-chassis / Oil
- Motor with fitted pulley – (attached)
- Sub-chassis (MDF damper arm & spring plates, glued washers)
- Power supply 230 volt or 110 volt (delete one)
- DC regulator board / switch
- Upgrade Transformer (optional)
- Sliding VTA adjuster, Aluminium sleeve, allen set screw (optional)
- Threaded VTA adjuster and packing washer (optional)
- Arm (optional)

PAPERWORK

- Turntable instructions
- Power supply instruction sheets
- Strobe card
- Upgrade transformer sheet (optional)

TOOLS YOU WILL NEED IDEALLY

- Ruler or measuring tape
- Marker pen.
- Small hacksaw or powerful snips
- Cross head screwdriver
- 3mm or 3.5mm drill
- Pliers or molegrips
- Hammer
- Soldering iron (not essential)
- Spirit level

Turntable assembly

PREPARATION

When you unpack the deck, check that you have all the parts listed in the parts list.

Undo the 2 transit bolts which hold the sub-chassis onto the topboard of the turntable plinth – see diagram below to identify the transit bolts.

DIAGRAM OF SUB-CHASSIS ASSEMBLY

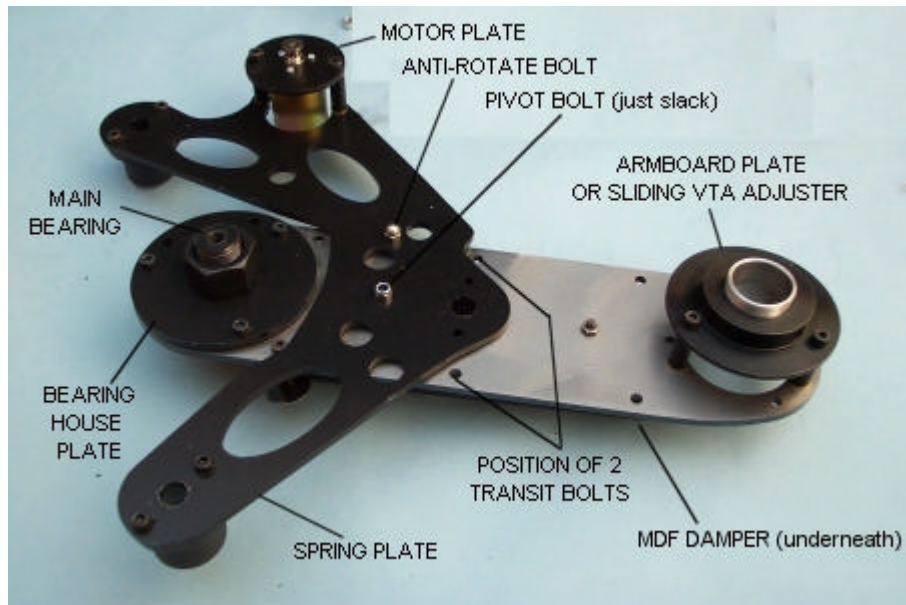

PLINTH AND LID ASSEMBLY

FIT THE RUBBER FEET

Fit the 4 rubber feet to the underside of the plinth – one foot at each corner. Use the 4 nails provided for this purpose – they only need to be hammered in till they are just below the surface of the rubber so as not to mark the surface the deck rests on.

DIAGRAM OF LID ASSEMBLY AND RUBBER FEET

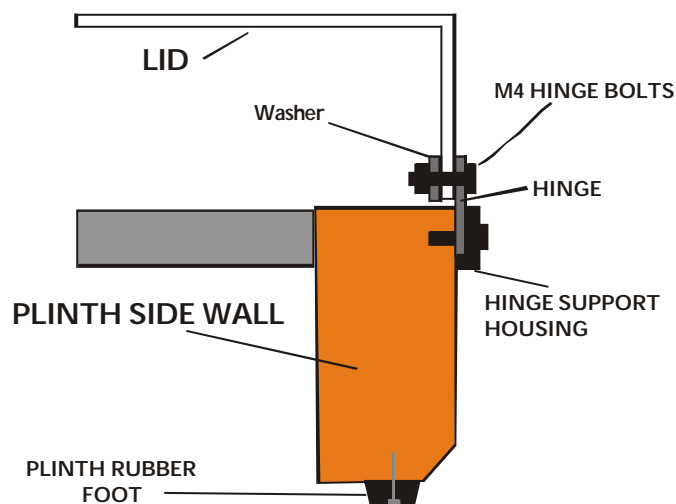

FIT THE LID

1. Fit the hinges onto the lid first using the four M4 bolts and nuts (see "diagram of lid assembly and rubber feet". There is a "hinge" portion that is fairly obvious to identify - this bolts to the rear outer side of the rear lid face - the bolts pass through the "hinge" then the lid and then a washer positioned on the inner face of the lid. The nuts then clamp the whole assembly together with the lid sandwiched in the middle.
2. Place the lid on the plinth and mark the positions of the screw holes for the hinge support housings using the lid as a jig. Ensure that the housing positions locate the lid centrally on the deck and at the correct height. The correct height is when the tops of the plastic housings are absolutely level with the top edge of the plinth.
3. Drill the holes for the hinge screws in the plinth using a 3mm or 3.5mm drill. -. The two hinge housings can now be screwed into position on the plinth – Re-insert the lid hinges to check the fit of the lid.
4. Pull the lid off the turntable to allow you to build the rest of kit – you can re-fit the lid once the deck is complete.

FIT THE SWITCH AND DC REGULATOR BOARD TO THE PLINTH.

1. Cut the switch shaft so that 10mm is left of it's smooth portion - use a hacksaw or powerful pair of wire snips. Remove the serrated washer from the switch and do not use it at all. The switch can then be fitted in position in the pre-drilled hole at the front left hand side of the plinth. You need only tighten the top clamping nut to the point that the switch body won't rotate when the shaft is clicked through it's 3 positions. Be careful not to cross-thread the nut when you put it on.
2. Fit the knob and tighten up the set screw in it's side to clamp it onto the switch shaft. A 2mm allen key is provided to tighten this set screw.
 - a) If you have the **advanced** dc regulator board then position it on the left underside of the plinth top-board (close to the walls of the plinth front corner). Mark the position of the centre hole in the board onto the underside of the plinth top-board – drill a shallow 3mm dia hole and screw the board into position with a No 6 x ½" screw. See diagram "Top view of wiring layout & connections" for position.
 - b) If you have the **standard** dc regulator board then position it on the left underside of the plinth topboard (close to the walls of the plinth front corner). Mark the position onto the underside of the plinth topboard for holes right on the edge of 2 opposite sides of the strip board – drill these shallow holes using a 3mm dia drill and screw the board into position with two No 6 x ½" screws and the brass washers such that the washers catch on the edge of the board and hold it on. See diagram "Top view of wiring layout & connections" for position.

TOP VIEW OF WIRING LAYOUT & CONNECTIONS

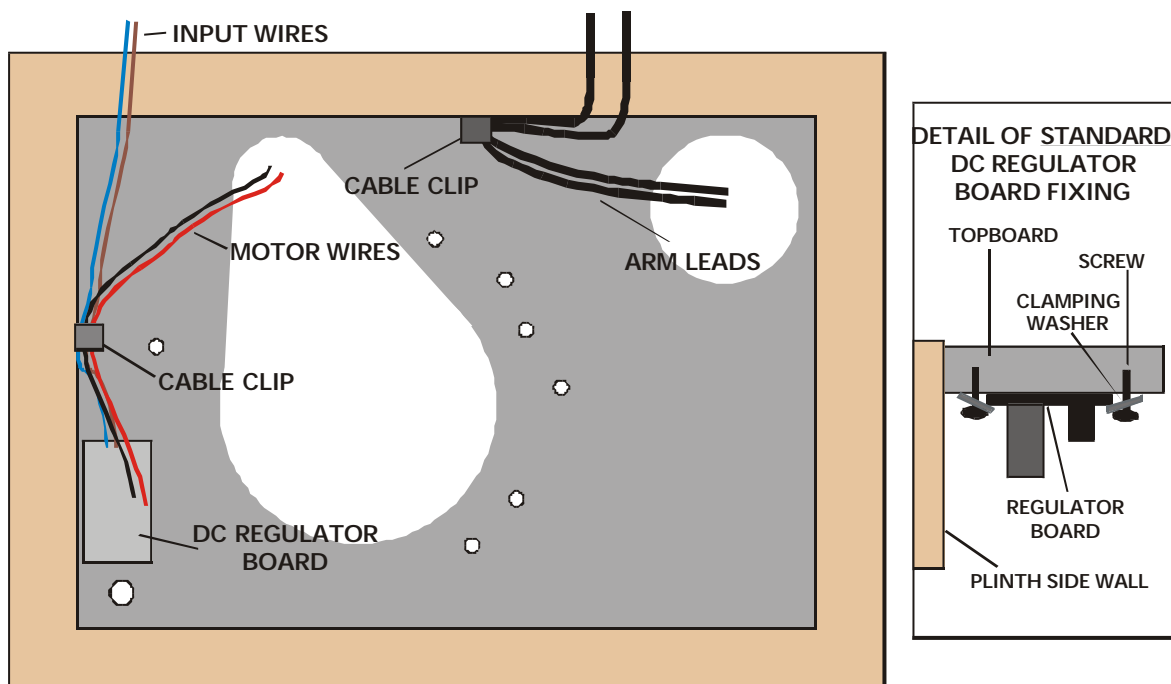

FIT THE 3 THREADED SUPPORT BOLTS

Fit the three M5 x 80mm threaded machine screw bolts (which support the springs) to the plinth topboard as shown below. Only "nip" the nuts tight by a maximum of 1/8 th of a turn after finger tightness has been achieved and they start to clamp onto the wood. You will probably need to check these have not slackened off after about 2 months as they tend to "bed into the wood initially.

DIAGRAM OF SUPPORT BOLTS AND SPRING ARRANGEMENT

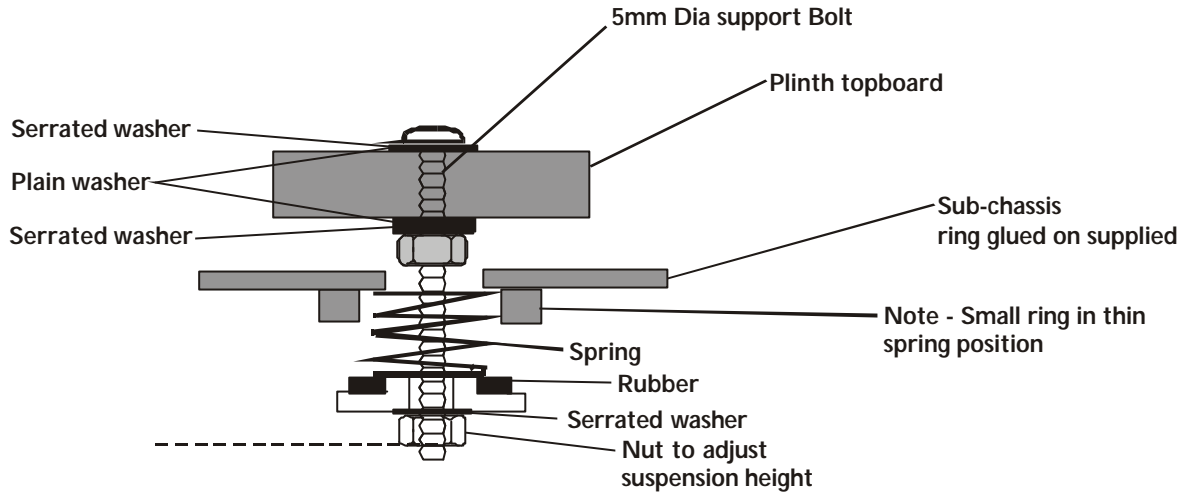

INSTALL THE SUB-CHASSIS

FIT BEARING HOUSE

Fit the bearing house to the sub-chassis as shown below - only "nip" the nuts tight with a pair of pliers - more force than this is detrimental to performance - the top of the bearing house should be approx 22mm from the top of the bearing house plate. Please note that ALL the bolts on the Sub-chassis assembly are carefully torqued to a correct tension at factory - DO NOT TIGHTEN ANY ALLEN BOLT SETTINGS OR IT WILL DEGRADE THE PERFORMANCE. ". The sub-chassis is attached to the "spring plate" by one "pivot bolt" - the two plates should be free to swivel and are loosely restrained by an "anti-rotate bolt" - this locating bolt on the side of the sub-chassis should not be tightened at all. The pivot bolt is tightened at factory and should not be tightened or the performance will degrade significantly.

DIAGRAM SHOWING BEARING HOUSE FASTENING ARRANGEMENT

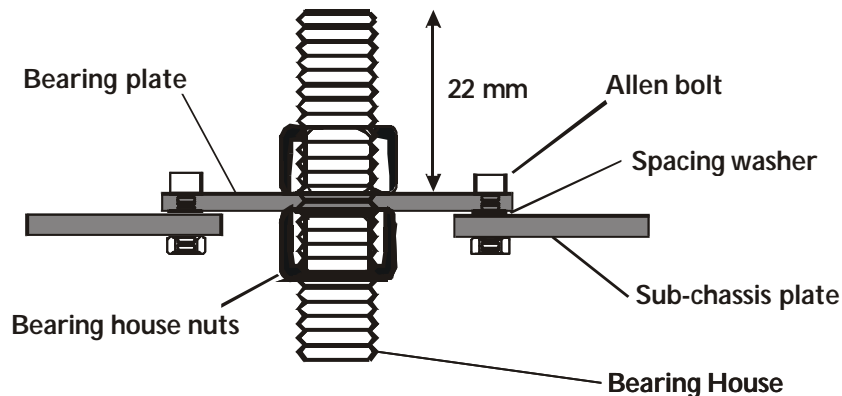

FIT THE MOTOR

Fit the motor to the motor plate using the 3 small machine screws supplied. These screws should be “just” tight to keep motor noise to a minimum. The motor fits on the underside of the motor plate – see “diagram of sub-chassis assembly”.

The motor plate is adjustable to enable optimum belt tension to be achieved – details of this are given in the motor installation notes but generally the optimum position is such that marker bolt in the “slot” is located at the mid point of the slot.

INSTALL SUB-CHASSIS & FIT SPRINGS

Offer up the sub-chassis assembly into the plinth and fit the springs as shown in the “ diagram of support rods and spring arrangement”. Each particular spring is of a different compliance and should be in the positions shown in the “diagram showing spring positions

DIAGRAM SHOWING SPRING POSITIONS

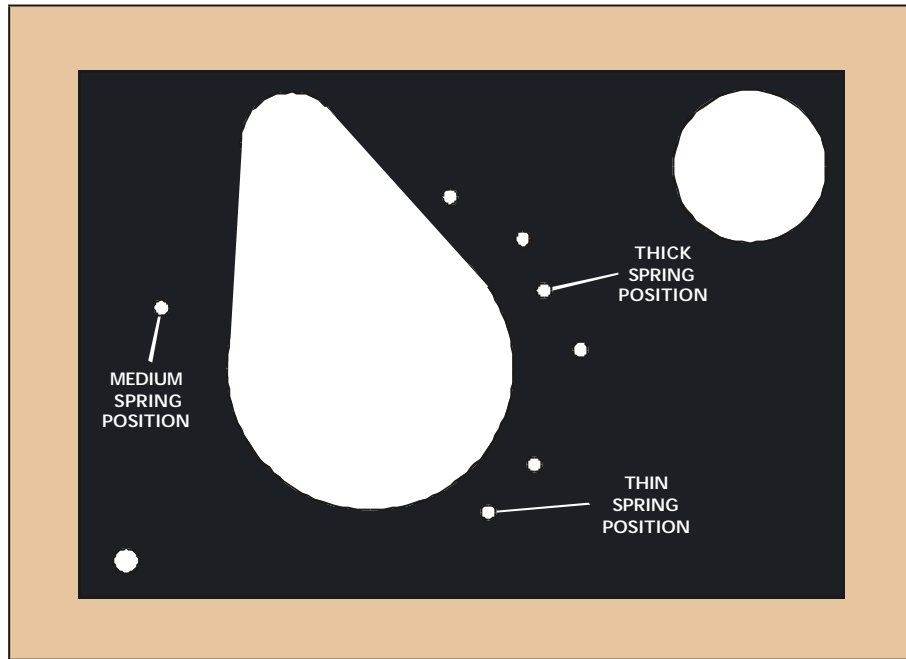

CONNECT THE MOTOR WIRES

Solder the red wire from the dc regulator board to the positive terminal on the bottom of the motor (this has a faint indented + sign alongside it). The black wire attaches to the other motor terminal. If you do not have a soldering iron then you can simply wind the wires round the terminal holes and glue them in position with a blob of evostick or similar – ensure that the wires do not make electrical contact with the motor body.

Lead the bullet connector wires out through the hole in the rear of the plinth and connect them to the power supply leads using the bullet connectors. These connectors may not look esoteric but they are made of copper as opposed to the brass commonly used in most connectors.

Screw one of the cable clips onto the inner side wall of the left hand side of the plinth (see “top view of wiring layout and connections”) such that it holds the input and motor wires (brown, blue, red & black) away from the sub-chassis and any danger of restricting its movement. For full details on the motor and power supply set up you need to read the separate sheets provided.

INSTALL THE ARM

It is necessary to fit the tonearm to the deck, before final “levelling” of the sub-chassis so that the weight distribution is correct. At this stage the arm simply needs to be in position – it does not need to be adjusted for height or have the cartridge fitted etc.

IF YOU DO NOT HAVE A VTA ADJUSTER

If you do not have a VTA adjuster then bolt the arm to the armboard now - you only need tighten the large bolt to finger tightness or very slightly tighter ("nipped tight 1/16 turn or less"). You will need to fit the arm "packing washer" underneath the large bolt or it will not "clamp" on the 4mm thick armboard.

It is NOT recommended to place the large serrated washer (supplied by Origin Live with OEM Rega arms or modification kits) under the large base nut as this does not work well with metal armboards.

IF YOU HAVE THE ORIGIN LIVE THREADED VTA ADJUSTER (WHICH FITS ALL DECKS)

Thread the adjuster onto the arm. Ensure that the threaded metal sleeve is the right way up with the recess on the top side. This ensures that the arm goes all the way down into the sleeve. It is NOT recommended to place the large serrated washer (supplied by Origin Live with OEM Rega arms or modification kits) under the large base nut as this does not work well with metal armboards.

Bolt the arm to the armboard - you only need tighten the large bolt to finger tightness or very slightly tighter ("nipped tight 1/16 turn" or less). You will need to fit the arm "packing washer" underneath the large bolt or it will not "clamp" on the 4mm thick armboard.

IF YOU HAVE THE ORIGIN LIVE VTA SLIDING ADJUSTER

Ensure that the Aluminium sleeve is the right way up with the recess on the top side This ensures that the arm goes all the way down into the sleeve. Place the arm in the aluminium sleeve and then clamp it in position via the set screw in the side of the VTA housing (i.e the sleeve is forced in to grip the arm's threaded base). You do not need the Rega nut on the base of the arm. Only tighten the set screw sufficiently to clamp the arm in position - over-tightening can make the arm sound bright. Do not fit a threaded VTA adjuster if you have the sliding adjuster.

FIT THE ARM CABLE

Fasten the arm cable - this should be supported by a cable clip screwed into position underneath the plinth - leave a slight droop on it so that it isn't "tight" (See diagram "Top view of wiring layout & connections" for position). This is helpful to minimise vibration of the cable. Avoid pulling the external wires at the base of tonearms as they are not indestructible and can become detached if excessive force is used to manipulate them.

You can use one hole or two in the rear of the plinth to lead out the external cable. For thicker leads you will need to use both holes. See picture "View of assembled kit from underside" at front of manual.

FIT THE CARTRIDGE

If you are new to fitting Hi-Fi cartridges please see the notes provided under the heading "Hi-Fi Cartridges - setting up procedures" but do not carry out any fine tuning at this stage as you only need the cartridge bolted to the headshell for arm height adjustment purposes.

INSTALL THE SUB-PLATTER & PLATTER

With the syringe supplied, run approx 5 drops of oil into the top of the bearing house. Wipe the sub-platter spindle surface to ensure that it is absolutely clean and very gently insert the sub-platter into the bearing house (If the oil does not overflow when the spindle touches the bottom then try 2 drops at a time till you just achieve overflow - wipe away excess oil) and then place the platter on top. The bearing needs a few minutes to "run in" and should run silent when truly vertical and full of oil - if it doesn't do so, there has probably been contamination with dust and you will need to clean it out with a lint free paper towel or similar wrapped around a thin rod. If you do this, be sure to also wipe the oil off the spindle as this also may contain microscopic contamination that is not visible.

Level up the platter using the nuts under the spring assemblies but only approximately at this stage. Ignore the fact that the spring support plate is not level - it hangs at a slightly different angle to the actual sub-chassis that supports the arm and platter - this is by design.

The top of the platter should be approx 31mm above the top of the arm board (or top of the VTA adjuster if present).

Fit the belt over the motor pulley and sub-platter after cleaning all the running surfaces with methylated or surgical spirit. Place the platter again on the sub-platter and level the platter by adjusting the nuts underneath the

spring seats. Ideally you should use a small spirit level for this purpose. You should also aim to get the top of the arm-board (or VTA adjuster) roughly level with the top of the plinth top-board. Note that the sub-chassis should bounce freely without contacting anything. It need only bounce up and down 1mm or so. Unlike some decks such as the LP2 you do not need to achieve an “even” bounce - the Sub-chassis takes most of the weight on one spring so it doesn't bounce very evenly.

TROUBLESHOOTING

Please note that very occasionally the bearing house will not be truly vertical due to slight variations of the thread pickup on the nuts. It is purely a matter of trial and error to get this right by rotating the nuts and bearing house slightly. Aim to get the platter parallel with the arm-board in at least the plane that affects cartridge “azimuth”. For definition of “azimuth” see section on “hi-Fi Cartridges – setting up procedures”. You can always alter the height of the arm to get the other plane true.

Be careful in moving or transporting the deck - it is possible to bend the spring supporting bolts if a severe side movement occurs (bear in mind that the sub-chassis etc. is quite heavy). Ideally it is best to use the transit bolts to hold the sub-chassis rigidly to the plinth topboard when transporting the deck. In the unlikely event of a sub-chassis foul on a support rod, the answer is usually to bend the bolt to the correct position. Only resort to such measures after you have checked all other possibilities such as springs not locating in their sub-chassis housings etc.

Set up of motor and power supply

In the first 4 hours of use from starting up the motor, the speed tends to drift but then settles down permanently. To burn in the regulator board components we recommend at least 4 hours of running the motor before you accurately set the speed.

To power up the motor and set the speed on the turntable – Refer to the separate sheets and notes provided.

Set up & maintenance of turntable

SET UP

Carry out a final check on the levelness of the platter with the turntable resting on the surface that is going to be it's final residence. It is best to use a spirit level for this purpose.

You can now move on to the section on “arm set up”.

NOTES & MAINTENANCE

NOTES

The Platter works best without any type of mat (including the Ringmat) or record clamp.

MAINTENANCE

The deck is not prone to going out of tune - we recommend that you check the level of the platter after the first few days as the springs initially need to “bed in” and every year or so after this.

Depending on your use of the deck, the belt should ideally be replaced every 2 years or so.

If you withdraw the sub-platter spindle you should put in a drop of oil to compensate for any possible loss.

Wow on the speed – can be caused by 3 main factors

- Insufficient belt tension

- Sub-platter “bottoming” on the top of the bearing house – check that there is a space of over 1mm or over so between the top of the bearing house and the underside of the sub-platter
- The brass insert at the bottom of the bearing house has somehow got lost – this is very rare but it is just possible – the bottom of the bearing house should be flat due to the presence of an insert sitting in the bottom – you can feel this with a long thin screwdriver or use a torch – if the surface is coned as you would expect in a drill hole then the insert is missing and you should request a new one.

Set up of tonearms

FINAL ARM SET UP AND NOTES

This section of the instructions apply to Rega arms and arms with similar mounting geometry – ie These arms require dimensions such that the centre of the platter to the centre of arm hole is approx 223mm plus or minus 2mm tolerance and the hole diameter for the arm is 24mm to 25 mm. The Completer Ultra kit is specifically designed for such arms – if you have something different such as a Linn arm (which requires a centre to centre distance of 211mm) then there are various ways to make the arm fit the deck. We do not at this time provide the armboard for this and so you will need to manage the solution on your own.

Please note that for the Origin Live Silver 250 tonearms - do not adjust bearing tightness - this is carefully set at factory - it may seem that there is slight “play” in the bearings - this is deliberate and must be left alone or degradation will result - it is not actually play in the bearings but carefully designed clearance tolerances of other components.

FIT THE CARTRIDGE (IF NOT FITTED ALREADY)

Fit the cartridge to the arm using an alignment gauge and ensure the headshell wires are bent so that they are clear of the record surface. If you are not familiar with fitting cartridges then please read the section “Hi-Fi Cartridges – Setting up procedures”.

SET TRACKING FORCE & SIDE FORCE BIAS

Ensure that the bias adjustment slider is set to zero. Set the tracking force to the manufacturer’s recommendations using a stylus force gauge (stylus balance). When tightening the counterweight, set it so that the Allen bolt is at the side of the arm (not at the top) see figure “Rear end view of counterweight” and tighten firmly - check tracking force is still correct after tightening.

Once the tracking force has been set you can set the sliding control for tracking bias - This should be set to be approximately equal to the tracking weight value. The settings you read on the arm are not always dead accurate so it may be worthwhile to fine tune the setting by ear using the centre track of a record.

USE OF STYLUS FORCE GAUGE

Most stylus force gauges work on the same principle as a set of scales or balances. For example with the Ortofon Stylus Force Gauge, first place the stylus on the inscribed or graduated portion of the scales. Then try the stylus at different points until you find the point where the beam “balances” freely in a roughly level position. You then read the force that is being exerted – (1gram = 10 mN if the scale is in mN). From this number you can assess whether you need to increase the tracking force or vice-versa. Move the tonearm counterweight accordingly and re-measure the tracking force. Repeat this procedure until the correct tracking force is obtained. The Shure stylus force gauge works slightly differently so follow the instructions that come with the gauge.

SET THE VTA (VERTICAL TRACKING ADJUSTMENT)

To allow the cartridge needle to track at the correct angle it is necessary that the base of the arm is at the correct height in relation to the platter. Usually the optimum setting is such that the TOP edge of the arm is parallel with the surface of a FLAT record – you can use a piece of card with parallel lines drawn on it to check this. Place the cartridge on the record with the deck switched off. Hold the card edge onto the record in a position alongside the arm and see whether the top edge of the arm is parallel. Raise or lower the base of the arm till you achieve parallel position. Most cartridges have a height of 17mm. If this is the case, the base of the arm should rest approximately 31mm below the top of the platter surface –see diagram “cross-section of sub-chassis”. If your cartridge height is different you can work out where the base of the arm should be from the preceding figures.

It is worth experimenting with VTA adjustment. Slightly raise or lower the arm and then listen - if the sound is relatively bright then the arm is too high, if it is relatively dull and bass heavy then the arm is too low.

- **If you have no VTA adjuster** Raise and lower the arm by fitting spacing washers under the arm. Alternatively you can raise or lower the height of the platter – this is easily accomplished by removing the platter & sub-platter to re-set the height of the threaded bearing house (see “diagram showing threaded bearing house arrangement”).

- **If you have the threaded VTA adjuster** Raise and lower the arm by rotating the VTA adjuster. If you find your arm is too high in relation to the platter with the VTA adjuster set to give the arm it's lowest position then you need to raise the height of the platter a few millimetres – this is easily accomplished by removing the platter & sub-platter to re-set the height of the threaded bearing house (see “diagram showing threaded bearing house arrangement”).
- **If you have the Origin Live VTA sliding adjuster** – Raise and lower the arm in the aluminium sleeve and then clamp it in position via the set screw in the side of the VTA housing (i.e the sleeve is forced in to grip the arm's threaded base). You do not need the Rega nut on the base of the arm. Only tighten the set screw just sufficiently to clamp the arm in position – over-tightening can make the arm sound relatively bright.

SET THE ARM FASTENING TIGHTNESS

It is best to experiment with the tightness of the large Rega base nut (if fitted) by listening to music. This may seem laborious but you will be richly rewarded as this adjustment is CRITICAL for performance. The mistake is often made of over tightening this nut with the result that the music is deadened.

WARRANTY

We guarantee arms supplied by ourselves to be free from fault for 2 years and will undertake to correct any faults providing the arm has not been modified by any party other than ourselves and has not received maltreatment of any kind. Our OEM arms and modifications are not guaranteed by Rega so in the event of a warranty claim you should contact ourselves rather than Rega.

NOTES

A detailed description of Cartridge set up and care is included in the end sections of this manual.

Please note that the occasional rewired arm can make a slight “rustling” noise through the speakers when it is lifted across the record. This should not be a cause for concern as it is only caused by microphony of the internal litz cable - under normal playing conditions this is inaudible.

The earth lead should be connected to the earth of your pre-amplifier or amplifier. This earth lead is best separated slightly from the arm signal leads so do not wind it around them for best performance.

Now that all the hard work is over you can settle back and hear the results - we wish you many hours of enjoyable music and rediscovering your record collection.

The sound of the deck will improve over the first 2 weeks or so as items “bed in” and the arm wires burn in.

REAR END VIEW OF COUNTERWEIGHT

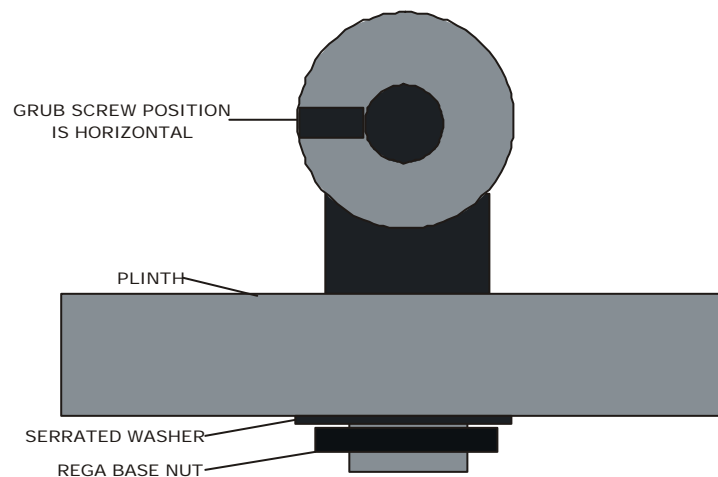

Hi-Fi cartridges - setting up procedures

INTRODUCTION

GENERAL COMMENTS

As we supply most makes of hi-fi cartridge we get asked questions from time to time about various issues regarding set up and care. To help newcomers to this area we have published the following notes. These guidelines are of a general nature - we publish them only to be of help and although widely accepted they are not formally authoritative - we cannot accept liability if you choose to use them and neither do we encourage the time consuming occupation of answering queries surrounding the procedures outlined - these are best referred to the manufacturer of your specific hi-fi cartridge.

For those new or inexperienced to fitting hi-fi cartridges we would state that this is NOT difficult and much of the detail and perfectionism outlined below is for those who like to experiment. We ourselves do not normally check azimuth, or vary tracking forces from the manufacturers recommendations - neither would we worry if the arm was up to 3mm away from the recommended distance from the spindle - although all these details are audible they are generally of a fairly low order, although tracking force and VTA are worth trying should you feel anything is lacking. If things seem complicated we would encourage you not to be put off as it all becomes clear once you get started.

Before fine tuning the set up as described below you should allow the cartridge to "run in" properly - at least 40 hours for some cartridges.

IMPORTANCE OF CARTRIDGE SET UP

Hi-Fi cartridges travel like a bobsleigh through the grooves of a record only a few thousandths of an inch wide. You hear groove displacements of the order of a few millionths. (That's like splitting a hair into one thousand pieces.) Every bit of motion or vibration allowed at this level can be heard enormously amplified through your speakers. For this reason it is good to set up the turntable and arm correctly so that the audio cartridge can do its job properly. For instance a turntable out of level can produce side forces on the pickup cartridge tip that will wear it more on one side than the other as well as have a slightly degrading effect on the wear of your records.

LEVELNESS

When a turntable goes out of level, the platter bearing performance and the arm's dynamics, specifically anti-skate, are negatively affected. So be sure your turntable platter and tonearm mounting board are level - use a spirit level. If the platter is out of level, first adjust the surface that the deck stands on. The suspension (in the case of a suspended sub-chassis design) may also need levelling if it has subsided over time.

HI-FI CARTRIDGES ALIGNMENT

Alignment for hi-fi cartridges needs to be optimised in three different planes. However, it cannot be perfect in all three planes, so it must be optimised for an overall best balance or compromise. The final authority should always be your ears and preferably over an extended period of listening time. Bear in mind that each record is cut slightly differently. Here again, optimise for an overall balance of good sound over a wide range of records. The three alignment planes are as follows. (Please note that it is the stylus, not the cartridge that is being aligned.)

- **Lateral tracking angle**

Viewed from above, the hi-fi cartridges arcing movement across the record must maintain the stylus in the same relation to the groove as that of the cutting stylus's straight-line tracking; this is Lateral Tracking Angle, or Tangency. Apart from linear tracking arms this is always a matter of the best compromise.

- **Azimuth**

Viewed from head on, the stylus must be perpendicular in the groove so as not to favour one groove wall, and therefore one channel, over the other wall/channel; this is Azimuth.

- **Vertical tracking angle (VTA)**

Viewed from the side, the stylus must sit correctly in the groove, at the same angle as the original cutter; this is Vertical Tracking/Stylus Rake Angle. VTA, however, varies from record to record. Therefore, this alignment must be set by ear, even more than is the case with the other adjustments).

HI-FI CARTRIDGE ALIGNING TOOLS

Tools required are an alignment gauge, a tracking force gauge, a FLAT record, a screwdriver or Allen keys of the right size (usually 2mm), a good light may also be helpful. Small needle-nose pliers and a magnifying glass all help. It also helps to have the hi-fi news test record. Treat the arm with care as some parts are fragile. To this end ensure that tightening of any bolts is carried out gently and without causing undue strain.

CHECK HI-FI CARTRIDGE CLIP CONNECTIONS AND MOUNTING

Tonearm wiring uses a standard color code for left channel (L) and right channel (R) and polarity. Coding is as follows: White = L Hot, Blue = L Ground, Red = R Hot, and Green = R Ground. If the cartridge pins aren't color-coded the same way, they will have letter identifications next to them. Make sure that the arm's wires, wire clips, and solder joints are in very good condition. At minimum, clean the contact between cartridge pins and wire clips by removing and replacing each clip. Holding the clips with needle-nose pliers can make this easier, but be careful that you don't strain the wires where they join the clip. Check the clips for a proper fit on the cartridge pins, and adjust them if necessary. "Proper" means snug but not tight. To check clip size, hold the cartridge tail-up close to the head wires, grasp a clip firmly right behind its tubular part with the tweezers, line it up with the cartridge pin, and press. If it does not slide on with moderate force, the clip needs opening-up. If it slides on easily but flops around when attached, it needs tightening. Sizing is the operation most likely to detach a clip. The trick is to avoid bending the wire at its attachment point or putting too much tension on it. To avoid either, always hold the clip with its wire slightly slack-looped behind it while adjusting. For opening a clip, hold it firmly with the tweezers or needle-noses, right behind its tubular section, and press the tip of the jeweler's screwdriver into the open end of its longitudinal slot until you see this widen very slightly. (Here's where you'll probably need the headband magnifier or reading glasses.) You're dealing with thousandths of an inch here, so a barely visible spreading may be all that's needed. Try it for fit, and repeat until it does. For tightening a clip, press a toothpick inside it as far as it will go, then use the needle-nose pliers to gently squeeze together the sides of the clip near its free end, while watching the slot for any change. (Attempting to squeeze a clip without the toothpick inside it will flatten its sides.) Try it for size, and resqueeze if necessary until the fit is correct. When it is, close up the middle section of the tube to match the end

Cartridge mounting screws (usually 2.5mm allen bolts) should be tight. Steel allen bolts are the best for mounting hi-fi cartridges - aluminum or brass are OK but difficult to tighten up hard (as they should be).

SETTING UP HI-FI CARTRIDGES

MOUNTING

Mount the hi-fi cartridge in the headshell if this is not done already. This is best done with the hi-fi cartridge stylus guard in place but it may be necessary to remove it during at least one phase of the installation. If you do, replace it as soon as possible. Be especially careful when the stylus guard is off, as many MC cartridges have a strong magnetic field at the base of the cantilever. If this attracts the tip of a steel-bladed screwdriver, it can destroy the stylus - there is no hope of resisting it. The best precaution is to keep the screwdriver well away from the cantilever, use a nonferrous screwdriver, or keep the stylus guard on when you're using the screwdriver near it. The other main hazard is children so don't forget to warn prying fingers.

The headshell screws should be finger-tightened just enough that the cartridge cannot fall off but still loose enough that the cartridge is easily moved around. Work whenever possible with the stylus's safety cap in place. Set tracking force at nominal, then do the tangency alignment procedures, then the azimuth. Do not deviate from this sequence as each step affects the subsequent one — change the order and the setup will be wrong.

TRACKING FORCE

This adjustment is carried out on the counterbalance weight of the tonearm or spring dial if one is in place. At this point, use your tracking force gauge and setting tracking force according to your cartridge instructions — final adjustment will be done later by ear.

If you do not have a tracking force gauge, but the arm does have a calibrated counterweight, defeat the arm's anti-skate mechanism or set it to zero. Set the counterweight so the arm is level and balanced. Be very careful of the unprotected stylus — you cannot do this with its safety cap in place. Once the arm is balanced, lock it in its cradle and, using the calibrated counterweight, set the tracking force according to your cartridge's recommended weight.

TANGENCY ALIGNMENT

(lateral tracking angle) - Follow the manufacturer's literature and the dictates of your alignment gauge — different gauges use slightly different methods. As you square up the hi-fi cartridge body with the gauge's markings, be sure that the cartridge sides are square or your alignment will be wrong. When all adjustments are correct, carefully tighten down the hi-fi cartridge mounting screws. Keeping a firm grip on hi-fi cartridge and headshell together so nothing shifts, delicately tighten each screw down a turn or so, then repeat until tight. Tightening down one screw all the way before tightening the others is almost certain to twist the cartridge out of alignment. However careful you've been, always check the alignment again after tightening.

VERTICAL TRACKING ANGLE (VTA)

Unless your tonearm has a special VTA adjuster, adjusting arm height is usually carried out with the use of spacing washers (as with Rega arms). In arms with a pillar / collar type vta adjuster it helps to put pencil or pen marks on the pillar to keep track of various heights. See your tonearm manual for its recommendations on adjusting arm pillar height. The best approach is to tune-in VTA gradually by listening to music. You know the arm needs to be lowered at the arm pillar when the overall sound is hard and bright, with thin bass or no deep bass, edgy highs, and harsh midrange (of course, this could also be tracking force which is too light). Distortion obscures low level details between the musical notes so dynamic range is reduced. Transient attacks may be too sharp. Raise the arm when the sound is dull and damped, the highs rolled off, the lows muddy and lacking definition, and transient attacks are dull. Mind you, this sounds an awful lot like the effects of changes in tracking force (too light is edgy, too heavy is heavy and dull). They are different sounding but hard to explain. Start with the arm a little low and very gradually raise it, first to where it is parallel to the record, and then so the back of the cartridge is tilting up. Keep track of your settings so you can return to the one you like best where everything snaps into focus. The range of adjustments can be quite broad, as much as 3/4" or even more (at the arm pivot). Play with the full range so you know what it sounds like and don't be diffident.

ANTISKATE FORCE (PIVOTING ARMS ONLY)

This applies an opposing, balancing force to the natural inward drag of a pivoting arm while playing. Left uncontrolled, the stylus would push up against the inner groove wall, causing distortion both from mistracking and a cantilever skewed in relation to the cartridge generator. To set, lower the stylus down near the label of a record with a wide run-out to it. Increase antiskate until the arm starts to slowly drift outward, away from the label. Again, this should be finalized by ear as you listen to music. If image placement is a little off-center, or if things don't seem to be locked in solidly, experiment with antiskate. Also, watch the stylus when you set it into a groove. Does it move to the right or left relative to the cartridge body? This indicates too much or too little antiskating.

FINE TUNING

You now have three adjustments approximated. Tracking force, VTA, and azimuth. It's a matter of reiteration to optimize the sound. The change in sound with each of these individual adjustments can be similar. It's therefore necessary, in optimizing all three, to experimentally move from one type of adjustments to the next, then to the next, in order to balance the optimization for all three. It's helpful to listen to female vocals as you proceed. Firstly try deviating from the cartridge's recommended tracking force by small increments - about 0.2 of a gram deviation above and below the manufacturer's basic recommendations. Don't worry about record damage from heavy tracking as most record damage is actually caused by mistracking in the middle-to-high frequencies with too little tracking force rather than with too heavy. If you're getting mistracking at the low (lightest) end of the range and yet the low range is generally sounding the best (and on moderate signals, not heavy passages), then chances are you have either a dirty stylus, a bad record, an accumulation of crud in your cartridge, or a cartridge that's getting old. Changes in tracking force can change how you want VTA and azimuth adjusted. If azimuth was initially adjusted by ear, experiment with it.

Proper care and maintenance of Hi-Fi cartridges & records

CARE OF HI-FI CARTRIDGES

Replace your cartridge when due - hi-fi cartridges have a lifespan for their cantilever suspensions and stylus needles. This will vary from manufacturer and type of cartridge as well as other factors like the cleanliness of your records and the care you take of the cartridge. It is wise to enquire on the expected life of your cartridge to the manufacturer, so that when the time comes it is replaced accordingly - most importantly this will preserve your records as well as enable you to enjoy the best performance.

If there is a build-up of dust and dirt where the needle enters the cartridge body you should use a small soft brush to brush the debris out. Always brush from the direction of the cantilever to the stylus or you may do damage.

Care of stylus - One well known method of cleaning styli is the Linn green stuff which is a very fine abrasive paper - this may be OK on some cartridges which do not have fine stylus tips and fragile cantilever mechanisms. However there is a danger of causing fractures or chips in your diamond stylus on certain fineline tips. This method can also strain the cantilever mechanism.

There are a number of fluids on the market that increase stylus life and help to clean gunge from the needle - a word of caution though - some of these can loosen the stylus glue on the cantilever over time - some fluids can also attack the cantilever or coil material itself or harden the suspension - consult your cartridge manufacturer over this. One key factor is to use the liquid very sparingly on a cotton bud such that it is just damp (not running with fluid) - this minimises the fluid which can run up inside the cartridge.

RECORD CARE AND CLEANING

The stylus itself does a pretty good job of cleaning the grooves and should itself therefore be kept clean. The proprietary brushes etc. for cleaning records will often do little more than brush dirt deeper into the record grooves and are best avoided if possible. Also keep records in high quality non-scratch record sleeves - preferably good ones.

A record cleaning machine is really the only answer for cleaning records properly as they suck out the debris and dust in the record grooves using a powerful vacuum. Tests using a microscope prove that this does the job with 100% success. The performance improvement is also very noticeable when it comes to even new records being played. We supply and highly recommend the Moth record cleaning machine as this is very effective from personal experience and comes with many glowing endorsements - see our web site for details and reviews.

ORIGIN LIVE, Unit 5, 362b Spring Road, Sholing,, Southampton, SO19 2PB U.K.
Tel:- 02380 578877 Fax:- 02380 578877 Owner:- Mark Baker C.Eng, BSc(Hons)MRINA
e mail: originlive@originlive.com web site: <http://www.originlive.com>